



**Energy Saving Technologies**

# **MINERAL WOOL SANDWICH PANELS**

Technical Catalog

CONTENTS

**CHAPTER 1. THREE-LAYER METAL PANELS WITH MINERAL WOOL INSULATION**

- 1.1 General .....3
- 1.2 Technical specifications ..... 3
- 1.3 Geometric characteristics ..... 3
- 1.4 Metal sheets for sandwich panels ..... 7
- 1.5 Base colors of panels the RAL catalog ..... 8
- 1.6 Filling of sandwich panels — mineral wool ..... 8
- 1.7 Basic technical parameters of sandwich panels ..... 9

**CHAPTER 2. GENERAL RULES FOR HANDLING, CUTTING, TRANSPORTATION, AND STORAGE OF SANDWICH PANELS**

- 2.1 Cutting ..... 11
- 2.2 Packing, transportation, and storage ..... 11
- 2.3 Preparation for installation ..... 17
- 2.4 Installation of wall panels ..... 17
- 2.5 Installation of roof panels .....18
- 2.6 Fastening of panels .....19
- 2.7 Installation of finishing elements .....23

**CHAPTER 3. CONSTRUCTION JOINTS .....24**

# CHAPTER 1. THREE-LAYER METAL PANELS WITH MINERAL WOOL INSULATION

## 1.1 GENERAL

PH Insulation manufactures sandwich panels with mineral wool insulation:

- for walls
- for roofs

PH Insulation wall and roof sandwich panels are used for external walling, internal partitions and false ceilings in

- production facilities
- agricultural buildings
- food processing facilities
- logistics centers
- office buildings
- sports buildings

All panels with mineral wool insulation are made in accordance with TU 25.11.23-013-7798324-2018.

## 1.2 TECHNICAL SPECIFICATIONS

In specifications PH Insulation panels are manufactured with the following catalogue code:

MW	XXX	X	X.X.X	-	X/X	X
1	2	3	4	5	6	7

Where

1. stands for type of insulation
2. stands for panel design: Panel for Wall Three-layer PWT, Panel for Roof Three-layer PRT
3. stands for type of lock connection: Z - standard lock for wall and roof panels, SF - with internal locking joint secret fix
4. stands for overall dimensions: length in centimeters, width and thickness in millimeters
5. stands for type of the outer type of metal of the sandwich panel
6. stands for type of the inner type of metal of the sandwich panel
7. stands for designation on packing lists or related documentation

Below is the example item code for a three layer MW wall panel with a length of 300 cm, a working width of 1190 mm and a thickness of 100 mm in a galvanized steel sheathing on the inside, in painted metal RAL 9003, on the outside  
MW PWT Z 300.1190.100 - Zn / Ral9003

## 1.3 GEOMETRIC CHARACTERISTICS

### WALL PANELS

The working width of wall panels can be 1190 or 1000 mm. Panel lengths vary from 2000 to 16000 mm at 10 mm increments. PH Insulation manufactures wall sandwich panels with a thickness of 50, 60, 80, 100, 120, 150, 170 and 200 mm. To give the panels extra rigidity, metal cladding is profiled. The types of profiling on different sides of the casing, as well as the templates of the sandwich panels are shown in the figures below.

Diagram 1.

Wall Sandwich Panel measurements (PWT Z)

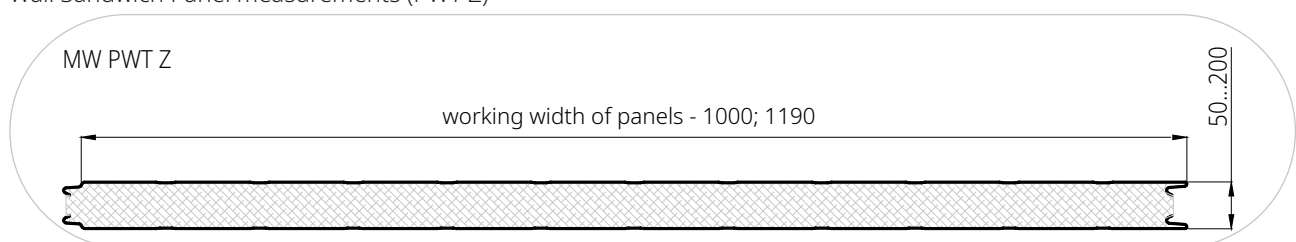

Diagram 2.

Measurements of a wall sandwich panel with internal locking joint SECRET FIX (PWT SF), dimensions are in mm

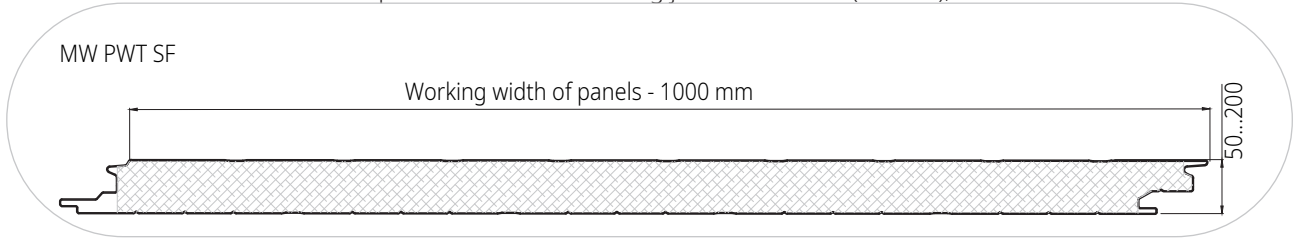

Diagram 3.

Joint of wall panels with Z-Lock fitting (PWT Z)

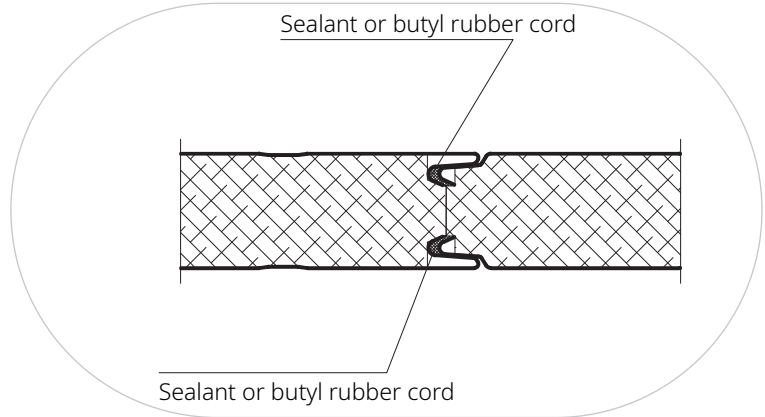

Diagram 4.

Joint of wall panels with internal locking joint SECRET FIX (PWT SF)

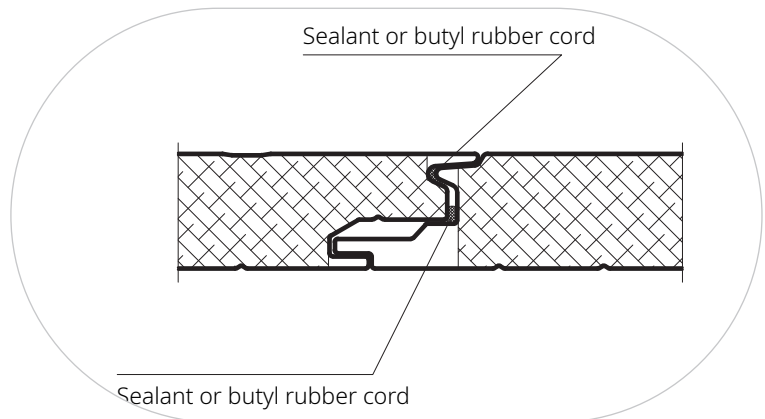
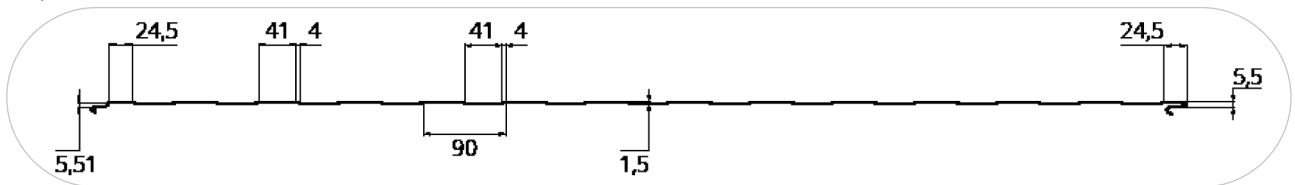

Diagram 5.

Types of profiles for the inner surface of the sandwich panels PWT Z, PWT SF, dimensions are in mm

Trapezoid PH



Trapezoid at increments 100 (T1)

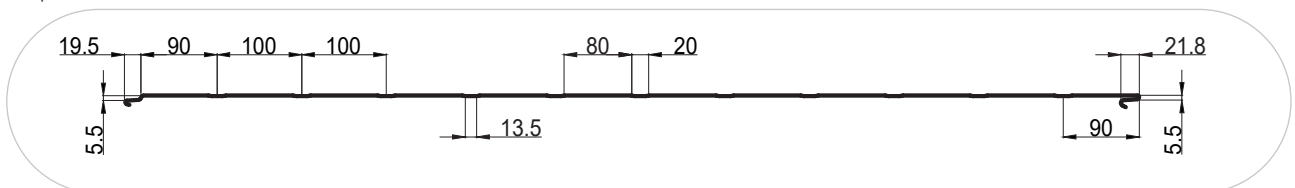

Flat (0)



Diagram 6.

Profiles of the exterior surface of PWT Z sandwich panels, dimensions are indicated in mm

Trapezoid PH



Trapezoid at increments 100 (T1)

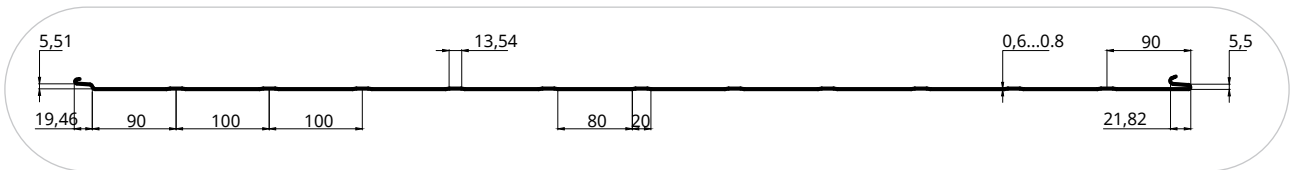

Trapezoid at increments 200 (T2)

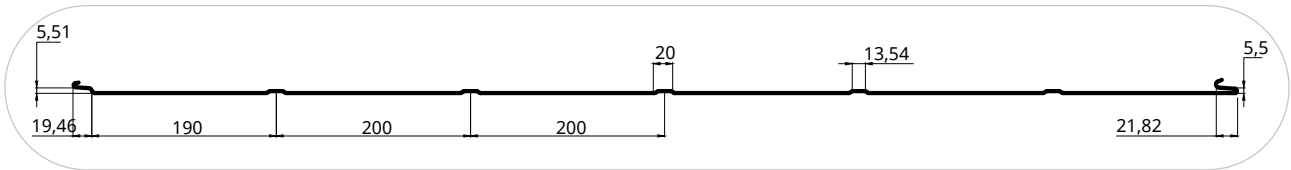

Flat (0)

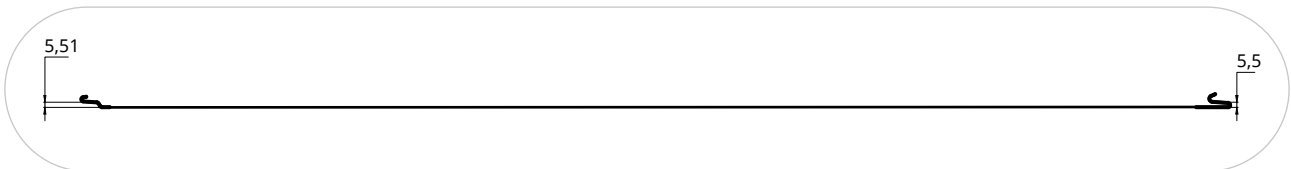

Diagram 7.

Profiles of the exterior surface of PWT SF sandwich panels, dimensions are indicated in mm

Trapezoid PH



Trapezoid at increments 100 (T1)

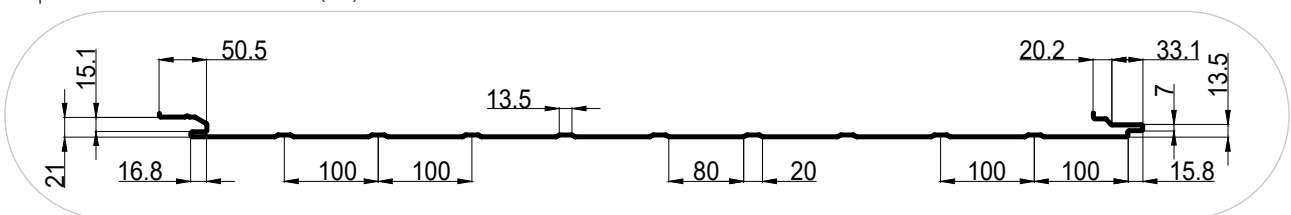

Trapezoid at increments 200 (T2)

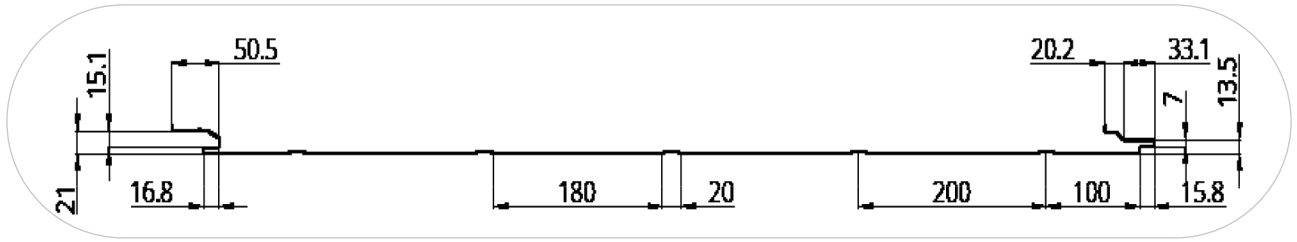

Flat (0)



**ROOF PANELS**

The working width of roof panels is 1000 mm. Panel lengths vary from 2000 to 16000 mm at 10 mm increments. PH Insulation manufactures roof sandwich panels with a thickness of 50, 60, 80, 100, 120, 150, 170 and 200 mm. To give the panels extra rigidity, metal cladding is profiled. The types of profiling on different sides of the casing, as well as the templates of the sandwich panels are shown in the figures below.

Diagram 8.

Measurements of roof sandwich panels (PRT Z)

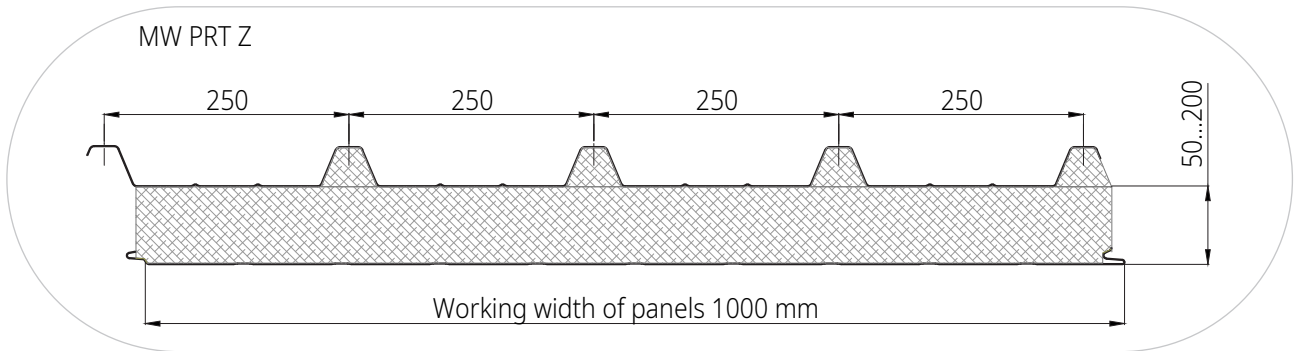

Diagram 9.

Joint of roof panels (PRT Z)

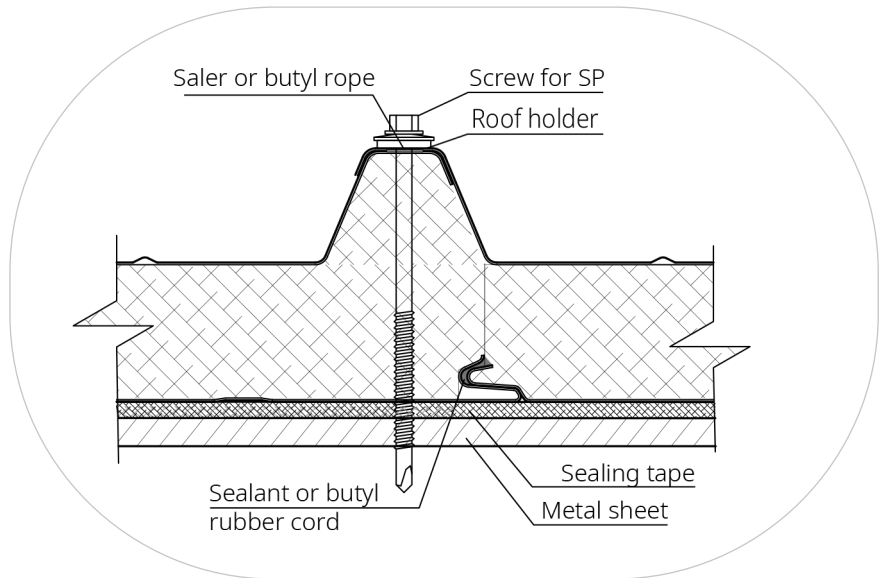

Diagram 10.  
Profile of the exterior surface of roofing sandwich panels (PRT Z)

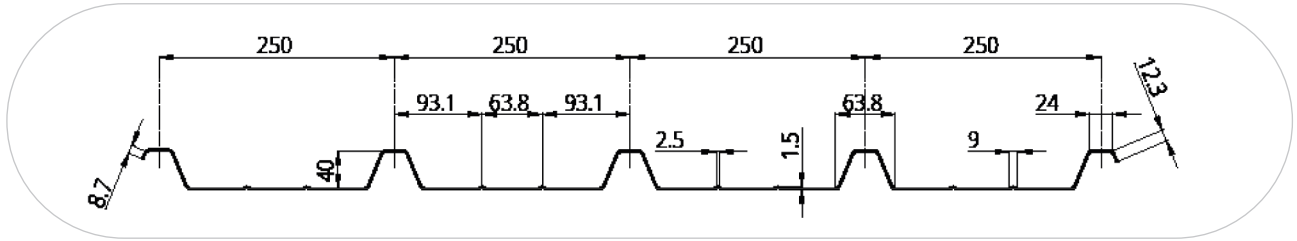
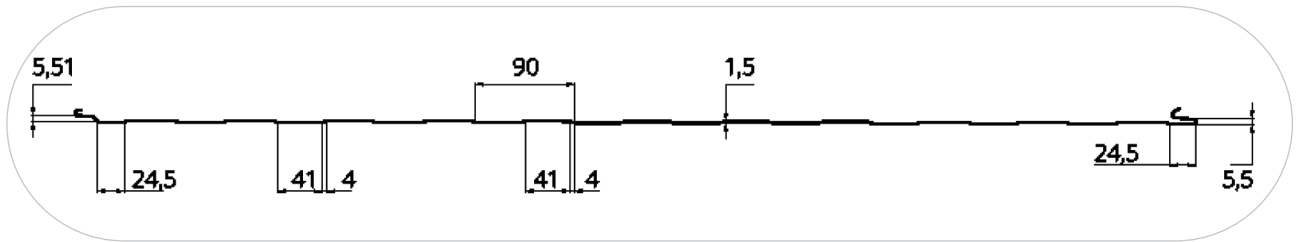
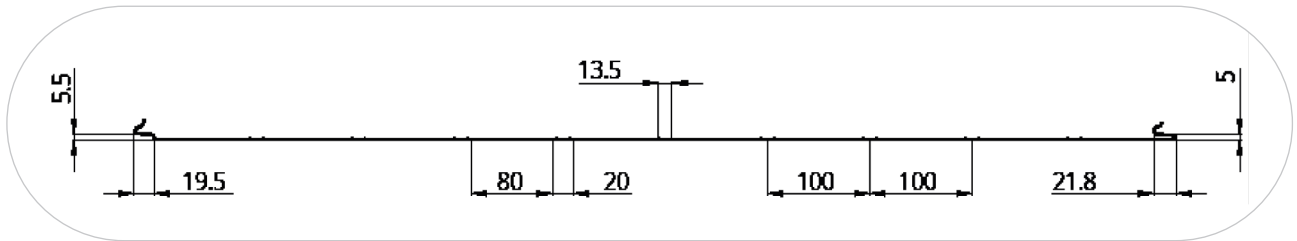

Diagram 11.  
Profiles of inner surface of roofing sandwich panels (PRT Z)

Trapezoid PH



Trapezoid at increments 100 (T1)



Flat (0)



#### 1.4 METAL SHEETS FOR SANDWICH PANELS

PH Insulation manufactures panels with metal sheets that meet the specifications listed in table 1.

Table 1.  
Specifications of Metal Sheets for Sandwich Panels

Metal Sheets	Minimum yield strength	GOST
Galvanized sheet	220 Megapascal	GOST 14918-80 GOST P 52246-2016
Galvanized sheet with a polymer coating	220 Megapascal	GOST 30246-2016 GOST 34180-2017 GOST P 54301-2011
Stainless steel	220 Megapascal	GOST 19904-90, EN 10088-1:2014

The type and thickness of the metal sheets are selected for each batch of sandwich panels. Minimum thickness of PH Insulation metal sheet panels is 0.5 mm, the maximum is 0.7 mm.

The material for metal sheets, with the exception of stainless steel, is first grade Group B rolled steel according to the Russian Standard GOST 14918-80, or foreign equivalents of rolled sheet steel with a protective anti-corrosion coating of zinc (Zinc), 5% aluminum-zinc coating (5 % Al-Zn), a coating based on aluminum, zinc and silicon (55% Al-Zn).

Organic-based coatings are selected depending on the durability requirements, as well as the purpose and operating conditions of the panels. Multilayer protective coatings are allowed. The thickness of the polymer coating (RAL) is 25-30 microns. The chemical composition of the stainless steel sheets and its physical properties comply with GOST 5632-14. PH Insulation uses stainless steel: AISI 304 grades for use in the food industry and AISI 430 for general use.

## 1.5 BASE COLORS OF PANELS THE RAL CATALOG

Table 2.  
Popular RAL colors

Name	Number
Ivory	RAL 1014
Light ivory	RAL 1015
Signal blue	RAL 5005
Leaf green	RAL 6002
Moss green	RAL 6005
Signal grey	RAL 7004
Light gray	RAL 7035
Chocolate brown	RAL 8017
Grey white	RAL 9002
Signal white	RAL 9003
White aluminum	RAL 9006
Colors of sandwich panels according to RAL Classic standard	

## 1.6 FILLING OF SANDWICH PANELS - MINERAL WOOL

Mineral wool is resistant to high temperatures and chemicals, it has good heat and sound insulation properties. The physical and mechanical properties of the mineral wool in PH Insulation sandwich panels are presented in table 3.

Table 3.  
The physical and mechanical properties of the mineral wool

Property , unit/value	Result
Density, kg / m <sup>3</sup> , not less than	95
Standard compressive strength, N/mm <sup>2</sup>	0.05
Standard tensile strength, N mm <sup>2</sup> , Rypcn, not less than	0.08
Standard shear strength, N / mm <sup>2</sup> , Rycn, not less than	0.04
The elasticity of the core material during compression Ec, N / mm <sup>2</sup>	3.2
The elasticity of the core material (tensile) Ec, N / mm <sup>2</sup>	3.5
Thermal conductivity at (298 ± 1)K W/m*K	0.041
Humidity, %/mass, not more than	1.5



## 1.7 BASIC TECHNICAL PARAMETERS OF SANDWICH PANELS

Table 4.  
Panel Weight

Panel thickness, mm	Panel weight with a 0.5 mm thick metal cladding and a filler density of 105 kg/m <sup>3</sup>			
	Roofing panel, width 1000 mm	Wall Panel, width 1000 mm	Wall panel, width 1190 mm	
	kg/ m <sup>2</sup> ; = kg/running metre	kg/ m <sup>2</sup> ; = kg/running metre	kg/m <sup>2</sup>	kg/running metre
50	15.032	15.063	13.566	16.008
60	16.082	16.113	14.616	17.247
80	18.182	18.213	16.717	19.735
100	20.282	20.313	18.816	22.203
120	22.382	22.413	20.916	24.681
150	25.532	25.563	24.066	28.398
170	27.632	27.663	26.166	30.876
200	30.782	30.813	29.316	34.593

Table 5.  
Thermal resistance of insulated panels R0 (m<sup>2</sup>\*C/W) for use in O conditions, not less than

Panel type	Panel thickness, mm	Reduced resistance to heat transfer in R0, m <sup>2</sup> .°C / W, for operating conditions «0», not less than
Wall panel Z Wall panel SF Roof panel Z	50	1.378
	80	2.110
	100	2.598
	120	3.085
	150	3.817
	170	4.305
	200	5.037

Table 6.  
Designed wind load of wall panels kgf/m<sup>2</sup> with metal cladding 0.5 mm thick and a temperature difference of 50 °C.  
Single span scheme (1/100 span)

Panel thickness, mm	Span width, mm									Support width, mm
	3.0	3.5	4.0	4.5	5.0	5.5	6.0	6.5	9.0	
50	151	129	89	60	40	27	17	-	-	
80	163	139	122	107	87	68	50	37	-	40
100	174	149	131	116	105	90	75	64	20	
120	203	149	153	136	122	108	90	77	37	50
150	232	199	174	155	139	127	113	96	50	60
200	261	224	196	174	157	143	131	121	67	70

Table 7.

Estimated wind load of wall panels kgf / m<sup>2</sup> with metal cladding 0.5 mm thick and a temperature difference of 50 °C. Double span scheme.

Panel thickness, mm	Span width, mm							Support width, mm
	3.0	3.5	4.0	4.5	5.0	5.5	6.0	
50	104	88	76	67	60	54	50	
80	115	97	84	74	66	60	55	60
100	126	107	92	81	73	66	60	
120	138	116	100	88	79	71	65	70
150	155	131	113	99	88	80	73	80
200	184	155	134	117	105	94	86	100

Table 8.

Designed load ( $q = q_{tech.} + Q_{sn.}$ ), Kgf / m<sup>2</sup>, of roofing panels (metal cladding thickness 0.5 mm) with a temperature difference of 20 °C. Single span design

Panel thickness, mm	Span width, mm					Support width, mm
	1.5	2.0	2.5	3.0	3.5	
80	460	339	267	218	184	60
100	578	427	336	276	233	70
120	696	515	406	334	282	80
150	873	647	511	420	335	90
200	1109	822	649	534	452	100

Table 9.

Estimated load ( $q = q_{tech.} + q_{sn.}$ ), kgf / m<sup>2</sup>, roof panels with metal cladding of thickness 0.5 mm and a temperature difference of 20 °C. Two-span scheme

Panel thickness, mm	Span width, mm					Support width, mm
	1.5	2.0	2.5	3.0	3.5	
80	340	248	194	158	132	80
100	409	302	237	192	160	90
120	481	356	279	227	189	100
150	577	428	335	272	227	110
200	718	534	419	340	284	120

# CHAPTER 2. GENERAL RULES FOR HANDLING, CUTTING, TRANSPORTATION, AND STORAGE OF SANDWICH PANELS

## 2.1 CUTTING

Sandwich panels should be cut with a jigsaw or circular saw, and a special blade for sandwich panels should be used. This makes the line of cut smooth and prevents jaggings (see Images 4 and 5). Do not remove protective foil before cutting.

Do not cut sandwich panels with an angle grinder!

## 2.2 PACKING, TRANSPORTATION, AND STORAGE

### PACKING OF SANDWICH PANELS

Metal faces of PH Insulation sandwich panels are protected with 35—50 µm polyethylene wrap, which should be removed after installation.

Please note that the removal of the wrap before the installation may lead to damaging of the panels. We also advise removing the wrap immediately after installation and no later than three months after the panel is manufactured. After this time, it may be difficult to remove the wrap, and panel coating may deteriorate.

Panels are stacked in packs up to 1,200 mm high. The number of panels in each pack depends on their type and thickness.

To prevent friction during transportation, cardboard sheets are used.

All packs contain a note with a packing list, where the order number, amount, size, type, and total weight of the panels is indicated.

### PACKING OF PANELS

Corners of packs are protected with vertical metal angles.

For roof panels, additional cardboard angles are added on the corners to protect them from friction during transportation.

The pack is wrapped with stretch wrap, and the upper layer of the coil is fastened. The overlap of the wrap in the layer is 35—40%.

The packs are placed on strong Styrofoam supports, 8 cm thick and 35 kg/m<sup>3</sup> dense. The number of supports depends on the length of the panels.

Diagram 12.  
Wall Sandwich Panels Packs

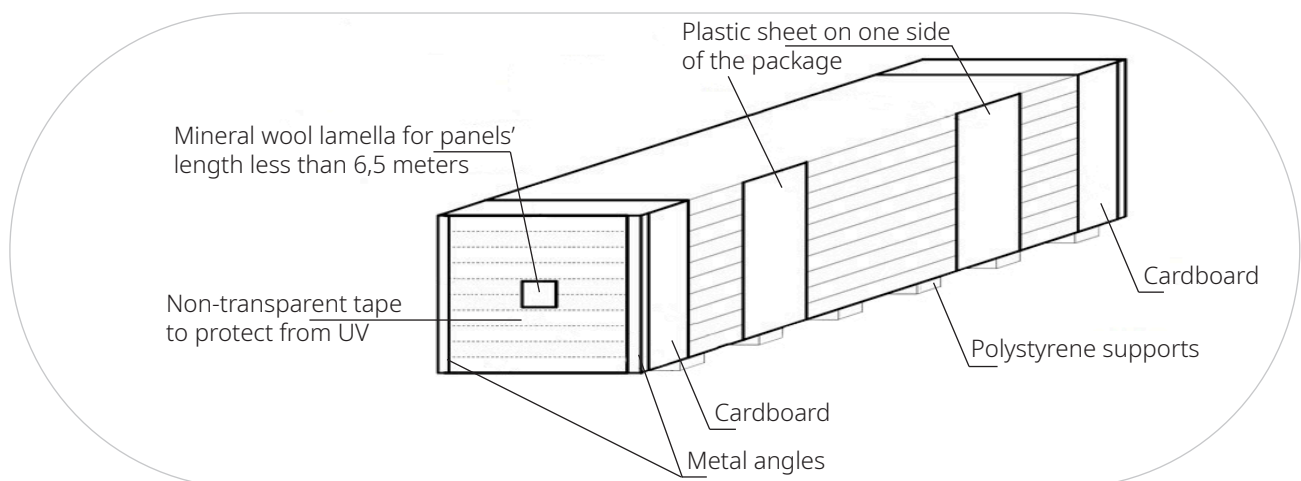
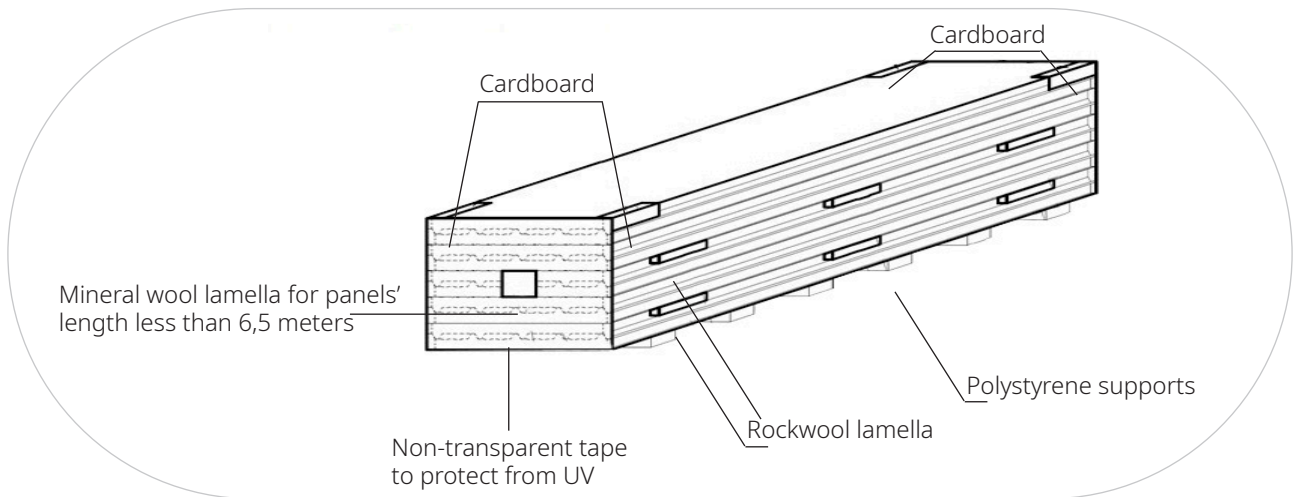

Diagram 13.  
Roof Sandwich Panels Packs



## TRANSPORTATION

### General considerations

PH Insulation will deliver the products to any destination in Russia and abroad by road, rail, and sea. This is the best option, because each load needs a carefully selected mode of transportation and responsible delivery service. PH Insulation uses online auctions to hire professionals for a reasonable price and safely deliver your order as soon as possible.

If you would prefer to arrange delivery of your sandwich panels independently, please make sure that the trucks of the company you choose are not equipped with self-engineered equipment (hacks, angles etc.); this may reduce the area of the body and damage the panels during transportation.

Loading of sandwich panels is performed from the sides, so sliding stakes should be placed on both sides of the truck.

The internal dimensions of the semi-trailer should be 13,600 × 2,450 × 2,600 mm (LWH). If they are even 2–3 cm smaller, the panels may not fit, and another truck may be required. Therefore, please make sure that the deliverer understands the importance of precise dimensions.

The body should be clean, flat, and free of foreign objects.

Ask the deliverer if the truck is equipped with any stakes for large-size and long loads, for example tubes or timber. These reduce the actual loading space, so the panels may not fit even if the dimensions of the truck meet the formal requirements.

The driver should bring 6–10 cargo straps. PH Insulation does not sell or rent such equipment.

During transportation, stability and fastening of the panels should be controlled, and loose straps should be tightened. Molded elements should not touch the surface of panels during transportation.

Do not put other loads on packs.

### MODE OF TRANSPORTATION

Most often, the panels are transported by road, in a flatbed truck, side truck, or covered truck. Please note that some vehicles are not suitable for the transportation of sandwich panels and doors for cold rooms.

Suitable options:

1. Flatbed trucks are suitable for short distances. If the distance is over 700 km, we strongly advise against this option because headwind and precipitation may damage the cargo.
2. Side trucks
3. Curtain or covered semi-trailers

### CONTAINERS

20' standard, 40' standard, and 40' high-cube cargo containers are available. If you want to transport PH Insulation products in a container, please notify your personal project manager in advance and pay attention to the internal dimensions.

Please note that some semi-trailers are NOT suitable for transportation of panels and doors for cold chambers due to construction features; it is physically impossible to load our products to such trucks. Therefore, we recommend

arranging the type of truck with the manager of your project in advance.

If a truck is equipped with a tail lift, the forklift will not be able drive close and properly load or unload packs of sandwich panels.

Side stakes will also be an obstacle, because the panels are loaded from the side.

If the truck is equipped with permanent or non-sliding stakes, it will be impossible to safely load the packs of sandwich panels or doors for cold storages.

#### CONTRACTORS

Some transportation companies on the delivery market are unreliable. Please make sure that your partner is trustworthy.

Check their constitutional documents and tax reports and look for references.

We advise against companies with a period of registration of less than a year or with a legal address in a place of mass registration.

#### STORAGE

Store sandwich panels on a flat surface (maximum 5% slope), up to two packs in a stack. The total height of the stack should not exceed 2.4 m. The upper pack should not extend beyond the bottom one. Place wooden supports (at least 10 cm thick) under the bottom pack with a maximum 1 m span between the supports.

Store sandwich panels in their waterproof factory package in an open or semi-closed warehouse and follow the fire safety procedures. Keep the panels away from moisture.

During short-term outdoor storage, protect the panels from direct sunlight, dust, and precipitation. Gently tilt the packs to prevent the accumulation of rainwater.

#### PLEASE DO NOT:

- put any loads on packs;
- put the second row of packs with a shift in respect to the bottom row;
- walk on panels;
- lift packs by the edge.

Table 10 shows the number of wall panels in a standard factory pack, and the number of packs in a standard truck.

Table 10.

The number of full packs of wall panels (width = 1,190 mm) in a standard truck with internal dimensions 13.4 × 2.45 × 2.6 m

Thickness of panels, mm	Panels per pack	Height of pack, m	Area of 16 packs, (L=3 m), m <sup>2</sup>	Area of 12 packs, (L=4 m), m <sup>2</sup>	Area of 8 packs, (L=5 m), m <sup>2</sup>	Area of 16 packs, (L=6 m), m <sup>2</sup>	Area of 4 packs, (L=3 m), m <sup>2</sup>
40	18	0.8	1024	1024	853	1024	683
50	18	0.98	1024	1024	853	1024	683
60	18	1.16	1024	1024	853	1024	683
80	14	1.2	796	796	664	796	531
100	11	1.18	626	626	521	626	417
120	9	1.16	512	512	427	512	341
140	8	1.2	455	455	379	455	303
150	7	1.13	398	398	332	398	265

Table 11.  
The number of full packs of roof panels (width = 1,000 mm)  
in a standard truck with internal dimensions 13.4 × 2.45 × 2.6 m

Thickness of panels, mm	3 m panels			4 m panels		
	Panels per pack	Height of pack, mm	Packs per truck	Panels per pack	Height of pack, mm	Packs per truck
30	22	1180	16	22	1180	12
40	18	1160		18	1160	
60	14	1200		14	1200	
80	10	1080		10	1080	
100	8	1040		8	1040	
120	8	1200		8	1200	
150	6	1100		6	1100	
200	4	960		4	960	

Table 12.  
The number of full packs of roof panels (width = 1,000 mm) in  
a standard truck with internal dimensions 13.4 × 2.45 × 2.6 m

Thickness of panels, mm	3 m panels			4 m panels		
	Panels per pack	Height of pack, mm	Packs per truck	Panels per pack	Height of pack, mm	Packs per truck
30	22	1180	8	14	780	6
40	18	1160		12	800	
60	14	1200		14	1200	
80	10	1080		10	1080	
100	8	1040		8	1040	4
120	8	1200		8	1200	
150	6	1100		6	1100	
200	4	960		4	960	

Image 7.  
Factory-packed sandwich panels

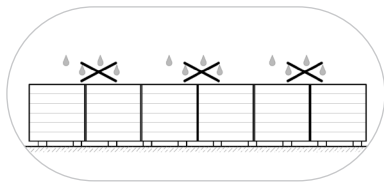

Table 13 shows the number of wall and roof panels in a pack depending on their thickness, and tentative weight of one running meter of panels in a pack.

Table 13.  
Standard factory packs of PH Insulation sandwich panels

Type	Panel thickness, mm	Panels per pack	Height of pack, mm	Weight of pack per 1 running meter, kg
Wall panels (width = 1,190 mm)	40	28	1210	328
	50	22	1190	268
	60	18	1170	228
	80	14	1210	191
	100	11	1190	161
	120	9	1170	140
	140	8	1210	132
	150	7	1140	119
	160	7	1210	122
	180	6	1170	111
Roof panels (width = 1,000 mm)	200	5	1090	97
	30	22	1190	191
	40	18	1170	198
	60	14	1210	165
	80	10	1090	126
	80	12	1290	151
	100	8	1050	107
	100	10	1290	134
	120	8	1210	114
	150	6	1110	93
		4	960	70

Table 14.  
General recommendations for storage of sandwich panels



Keep away from moisture.  
Control package integrity.

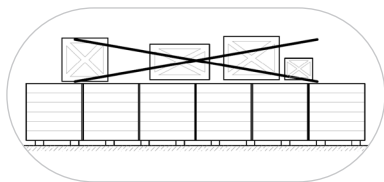

Do not put other objects on the surface of panels.

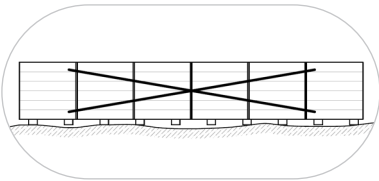

Store panels on a flat surface.

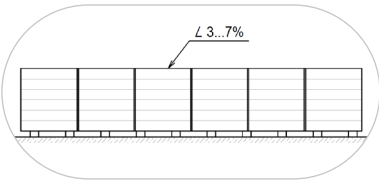

Avoid overhanging of the second row.

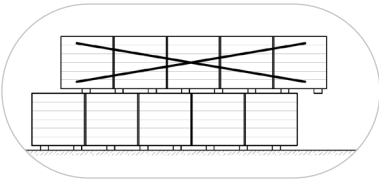

Do not walk on panels.

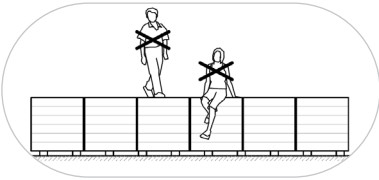

Protect panels from direct sunlight.

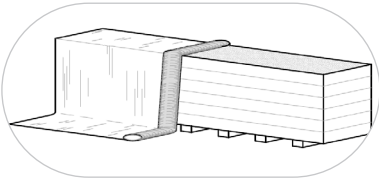

Lift packs one by one.

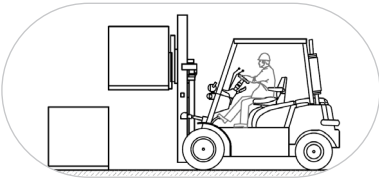

Do not lift by the edge.

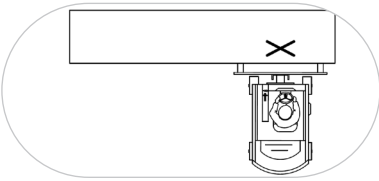

Do not jolt.

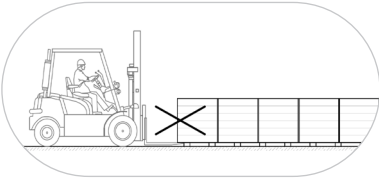

Avoid contamination.

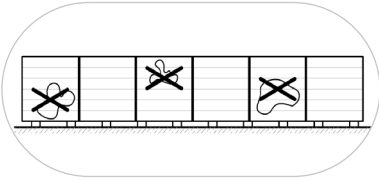

Place the panels with a gentle lengthwise slope.



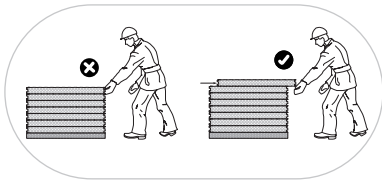

Do not lift panels by the lock

## 2.3 PREPARATION FOR INSTALLATION

Before installation:

- Read the project documentation, including panel layouts; solutions for individual nodes; specifications for molded, joint, sealing, and finishing elements; and installation diagrams and procedures;
- Check if the size of panels complies with specifications;
- Examine the panels for signs of damage and corrosion;
- Clean the construction site of debris; remove unnecessary items;
- Check if load-bearing structures and positioning points comply with project documentation; pay attention to horizontality, verticality, flatness, parallelness, and damages. Restore anti-corrosion coating of the metal framework if necessary.

Comply with all applicable safety regulations and rules.

Please do not:

- Use flame cutting equipment. Cut panels with circular saws or jigsaws only and remove metal shavings immediately after cutting;
- Clean sandwich panels with acidic or alkaline solutions and abrasives;
- Walk or drive on panels.

Lift panels with a vacuum gripper or a crane with soft slings only. Place wooden bars of at least 1.2 m long under and on the packs of panels at equal distance. The slings should not grip the package. To avoid damages of locking elements, do not lift individual panels from pallets.

Do not lift panels by the lock, lift them only by the lower facing. To do this, you first need to move the panel horizontally (See Table 14)

Panels should be balanced when grappling and lifting. Move them in a smooth manner without jerking, bouncing, or rotating. Fasten anchoring lines to the ends. First, lift the panels to a height of 30 cm and check the fastening of slings and safety belts. After that, lift the panels to the site of installation.

Avoid deflection of panels and deformation of locks when lifting and moving. Install the panels to their standard positioning points with consideration for project tolerances.

Remove protective foil from panels within four days of installation and within three months of the date of manufacture. Do not remove the foil if the environmental temperature is extremely low or extremely high.

## 2.4 INSTALLATION OF WALL PANELS

The installation procedure fully depends on the type of construction.

In case of vertical layouts, start from the first panel adjacent to the corner joint. In horizontal layouts, install panels from the bottom with tongues directed upwards.

When necessary, finish the installation of vertical or horizontal rows with molded panels. The size of molded panels depends on the project and is to be specified on site. These panels can be cut for final adjustments. Make sure that the marking line is precisely horizontal. Cut the metal face first, then cut the insulation layer. Clean surfaces and locks of shavings and dust after every drilling and cutting. Protect panels from contact with other elements of construction with sealing tape or a layer of mineral wool.

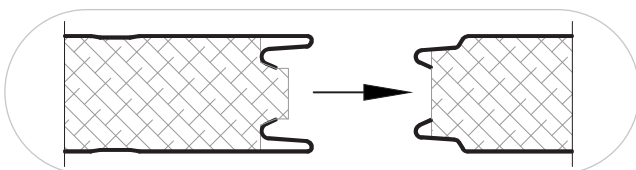

Firmly press the locking parts of vertical panels to each other. When installed horizontally, the locks are pressed by the weight of panels. The width of the locking joint should not exceed 1—3 mm. Seal the edge of the lock with a silicone sealer or a highly adhesive butyl rubber rope. Protect the joints from external stress using molded elements specified in the project. Place cover strips with an overlap and then seal the joint.

## 2.5 INSTALLATION OF ROOF PANELS

Roof panels are installed with a slope of  $>7^\circ$  at the final stage of roof construction.

Before installation, prepare a working site on the top of load-bearing elements, cut off insulation extending from under the faces, and clean the elements of mold, rust etc. Protect metal elements with an anti-corrosion agent; impregnate wooden elements and protect them with a flame retardant.

Place sealing tapes (3—4 mm thick and least 10 mm wide) on purlins. Install panels across the purlins parallel to the eave. If the slope of the roof is over  $15^\circ$ , place additional barriers on the eaves to prevent panels from sliding.

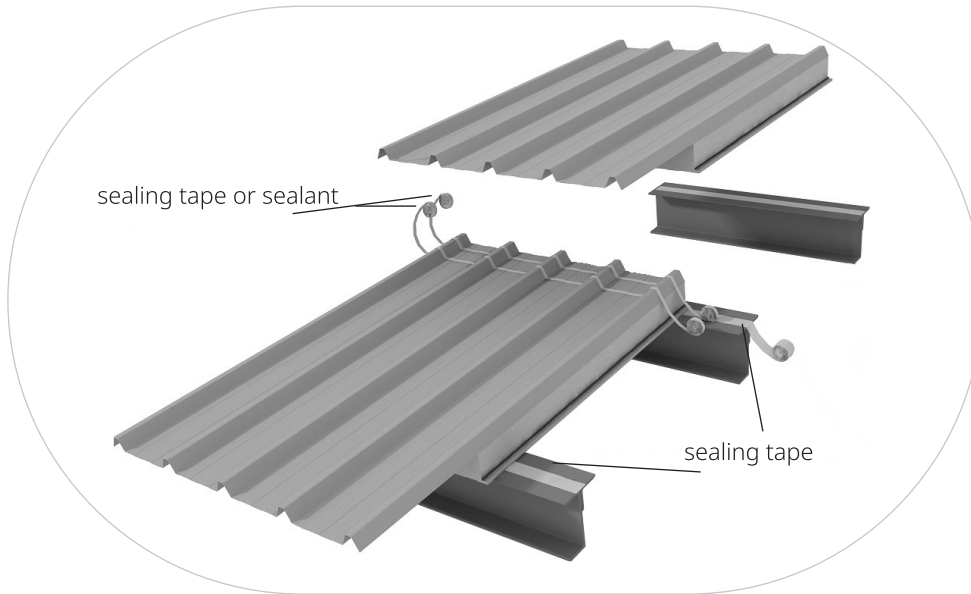

The first panel is installed with its hollow rib at the side wall of the building.

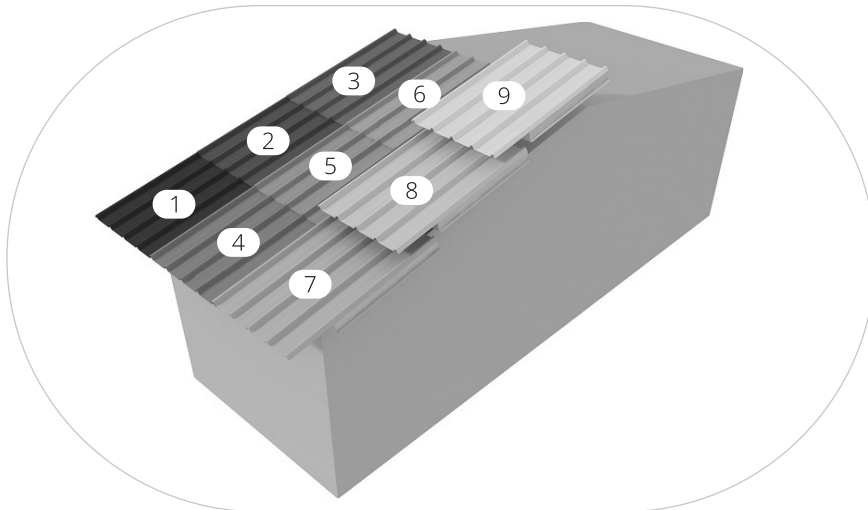

If the size of the roof exceeds the dimensions of panels, install the panels from a lower point towards the ridge of the roof, in the direction specified in construction procedures. Place the rows of roof panels with a 200-300 mm longitudinal overlap, depending on the slope. To prepare the second and subsequent rows of panels:

- Cut the lower face at the width of the overlap;
- Remove the layer of insulation.

Place two parallel rows of sealing tape or butyl sealant on the overlapping section of lower panels. Apply the sealant on the locks and on the top of outermost ribs of lower faces of installed panels. Do not apply too much pressure. Leave a 1—3 mm gap between the panels to avoid bulging of locking joints.

## 2.6 FASTENING OF PANELS

All joints between panels and open areas of insulation must be closed with shaped elements.

Fasten panels to metal constructions with screws; the number of screws is usually specified in the project

documentation. Washers of tightened screws should be in close contact with the surface and strictly parallel to it; avoid deformation of washers.

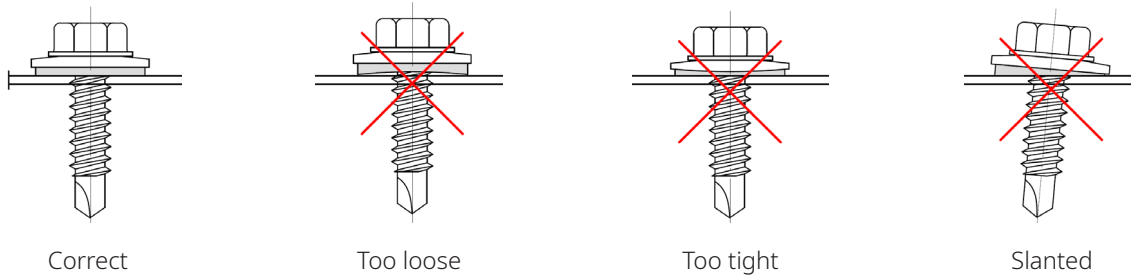

Table 15.  
Suggested screws for PST Z panels of different thickness

Thickness of wall panel, mm	Screws for constructions up to 12.5 mm thick
50	Screw for SP 95
60	Screw for SP 115
80	Screw for SP 130
100	Screw for SP 160
120	Screw for SP 190
150	Screw for SP 210
170	Screw for SP 240
200	Screw for SP 285

Sandwich panels equipped with Z-Lock system are fastened according to project documentation (about 3 pieces per panel).

To ensure the best fit panels to the purlins at the joints of the panels, it is recommended to fasten the screws through the roof holder.

Diagram 14.

Wall panels with Z lock, first row. Horizontal installation options for frame fachwerk building.

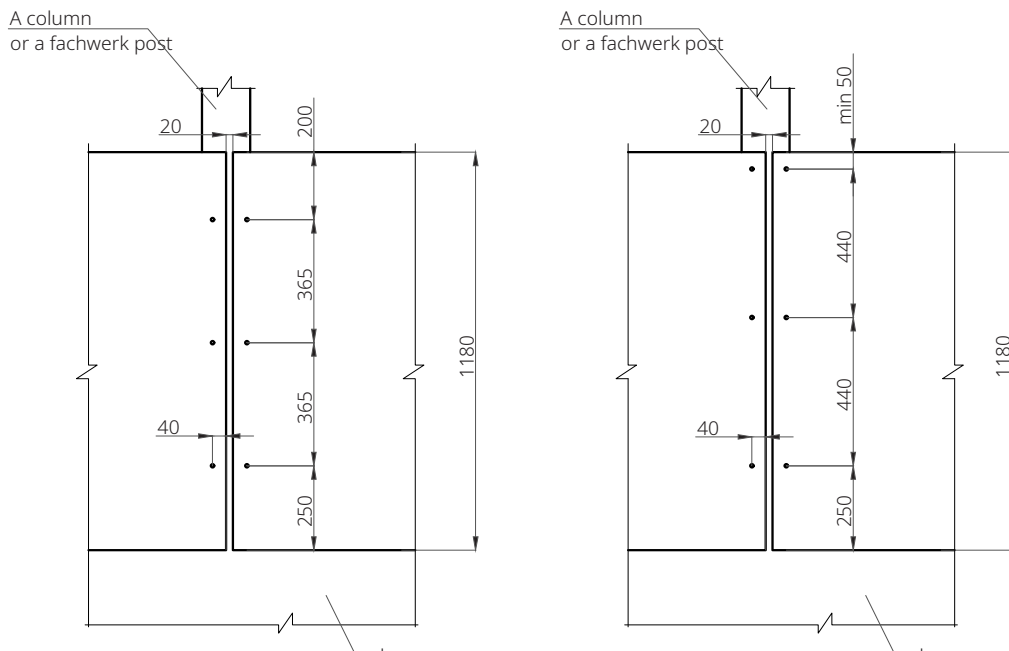

Diagram 15.  
Wall panels with Z lock, second and subsequent rows. Horizontal installation options for frame fachwerk building.

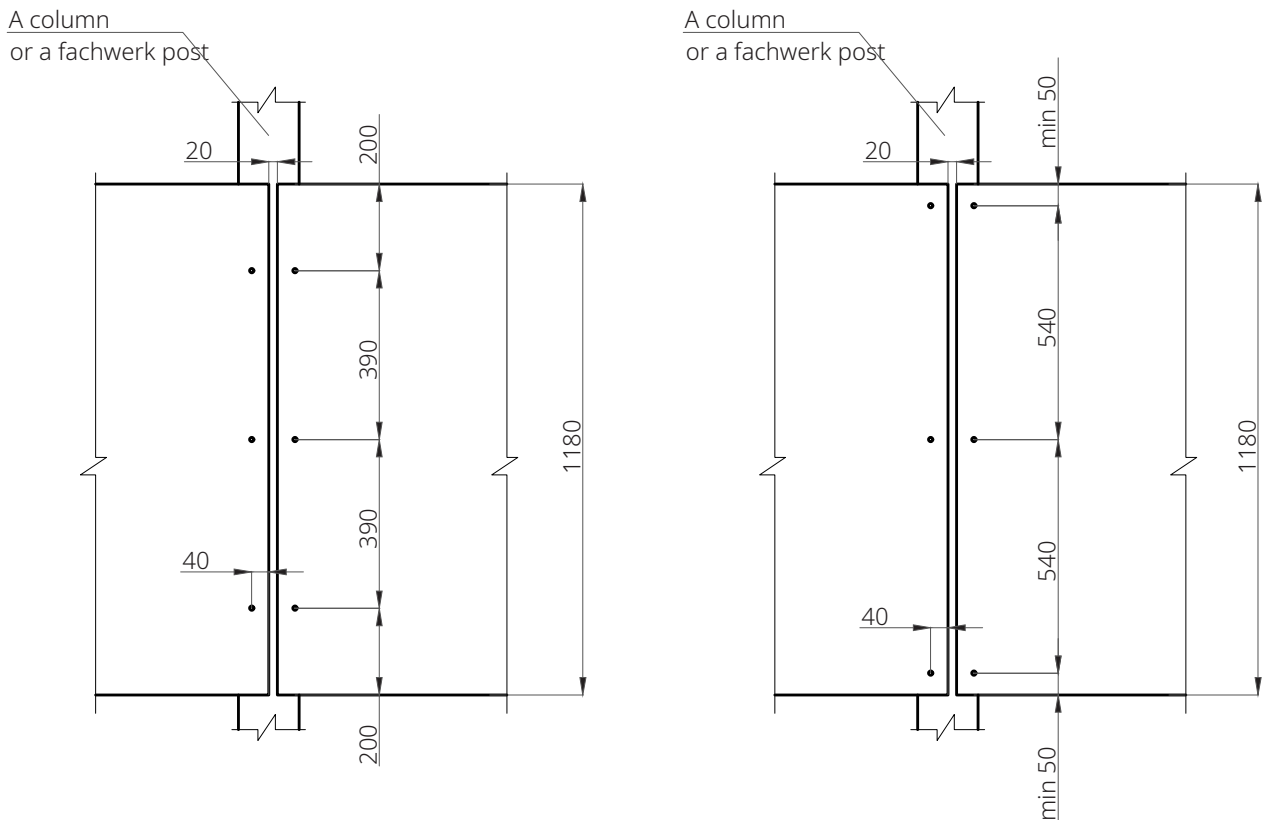

Table 16.  
Suggested screws for roof panels of different thickness

Thickness of roof panel, mm	Screws for constructions up to 12.5 mm thick
50	Screw for SP 140
60	Screw for SP 160
80	Screw for SP 190
120	Screw for SP 210
150	Screw for SP 240
170	Screw for SP 285
200	Screw for SP 315

It is better to fasten every rib in the outermost rows to every purlin, because these panels are prone to the highest wind load. The middle rows may be fastened to every second purlin if the distance between the purlins is less than 1.5 m. Place sealing tape or sealing foam on the joint along the outermost rib, under the hollow rib of the next panel. In the lock area, panels should also be fastened with screws for molded elements or with pop-riquets as seen on Diagram 17, cross-section 2-2.

Diagram 16.

Section of the outermost and subsequent rows of roof panels along the purlin; places of cross-section are shown.

- |                               |                                 |
|-------------------------------|---------------------------------|
| 1. roof panel                 | 4. purlin                       |
| 2. screws for sandwich panels | 5. sealant or rubber butyl rope |
| 3. sealing tape               | 6. sealing tape or foam         |

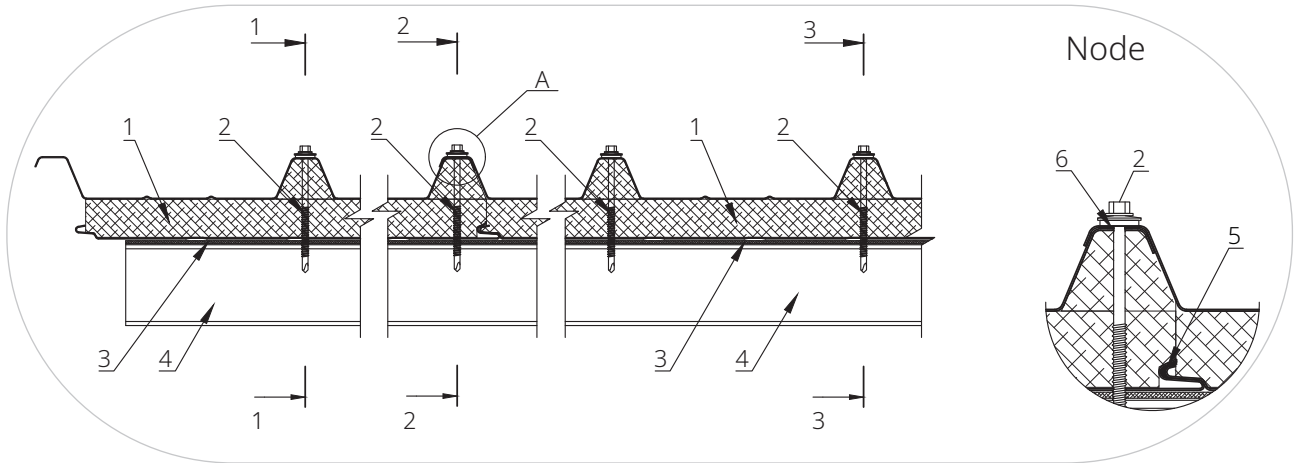

Diagram 17.

Sections of roof panels. Recommendations on fastening

- |                               |   |
|-------------------------------|---|
| 1. roof panel                 | 4. purlin                                   |
| 2. screws for sandwich panels | 5. sealant or rubber butyl rope             |
| 3. sealing tape               | 6. pop-rivets or screws for molded elements |
|                               | 7. sealing or butyl tape                    |

Section 1-1.

Fastening of outermost panels

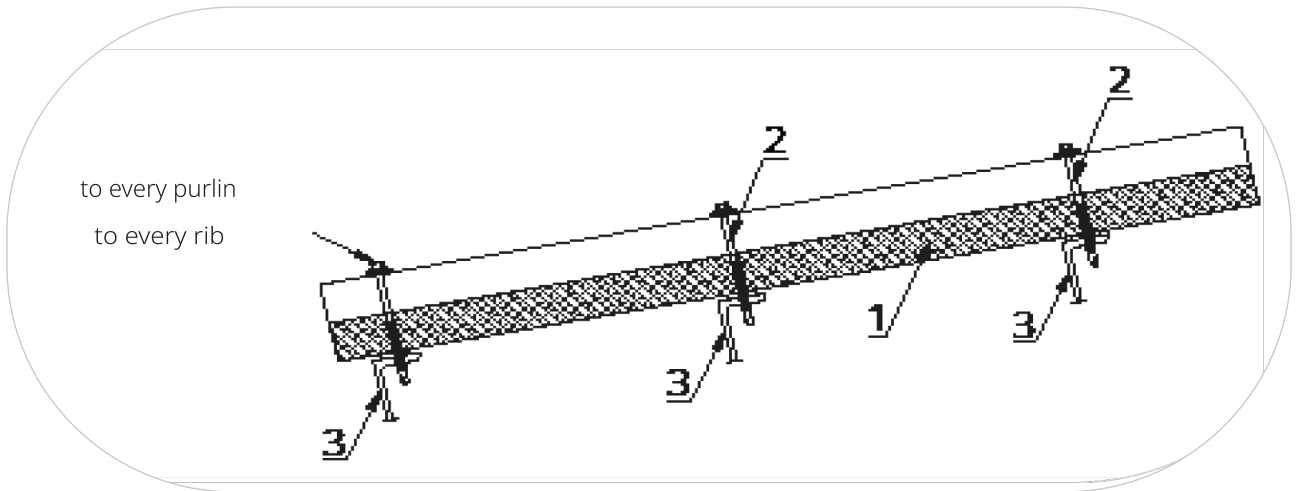

Section 2-2.  
Fastening in the lock

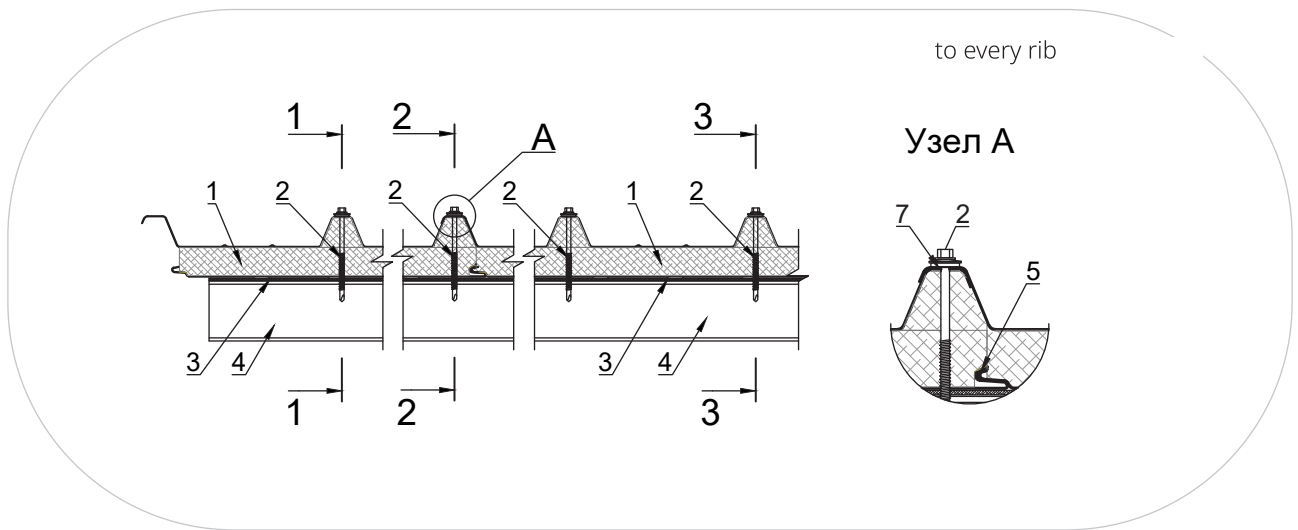

Section 3-3.  
Fastening of middle panels

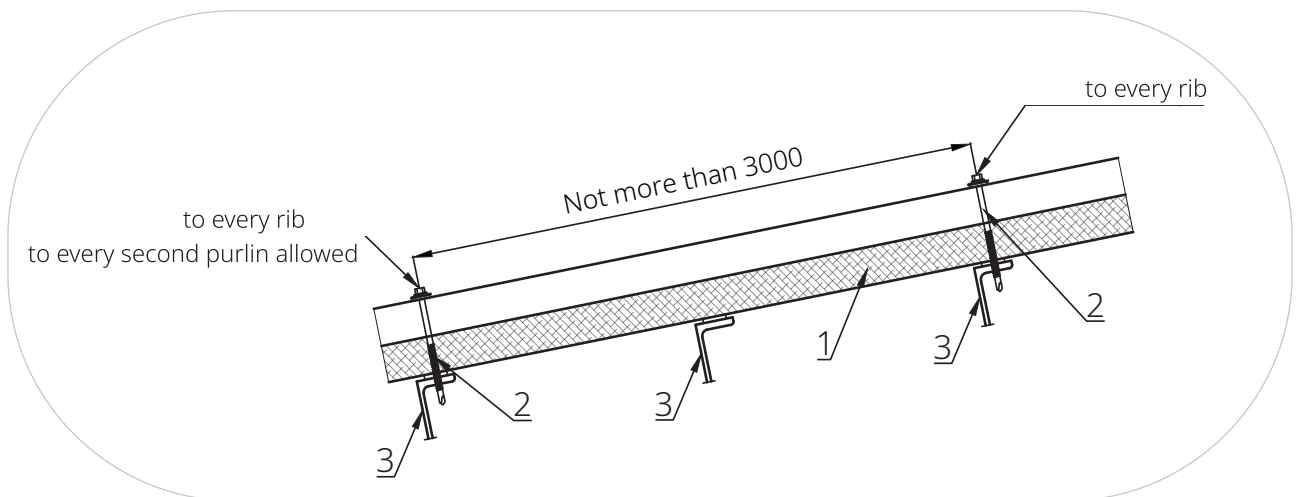

**2.7 INSTALLATION OF FINISHING ELEMENTS**

Install finishing elements with an overlap according to the project (usually from the bottom of the building to the ridge of the roof) and seal the joints. Cut and adjust the elements on site if necessary and apply a sealant for outdoor use along the adjacent surface of panels.

Do not leave any gaps and slits.

# CHAPTER 3. CONSTRUCTION JOINTS

## JOINT 1. VERTICAL JOINT – HORIZONTAL ARRANGEMENT OF THE PANELS

- |  |  |
|--|--|
| 1. sandwich panel  | 6. sealing tape  |
| 2. metal sheet construction                                  | 7. shaped element                                      |
| 3. expansion gasket  | 8. sealing compound or butyl latex sealing tape        |
| 4. polyurethane foam   | 9. fastener for fastening shaped elements or pop rivet |
| 5. mineral wool core or lightweight grade<br>fiberglass core | 10. screws for sandwich panels                         |
|  | 11. impact anchor                                      |

Option 1.  
Metal sheet fastening

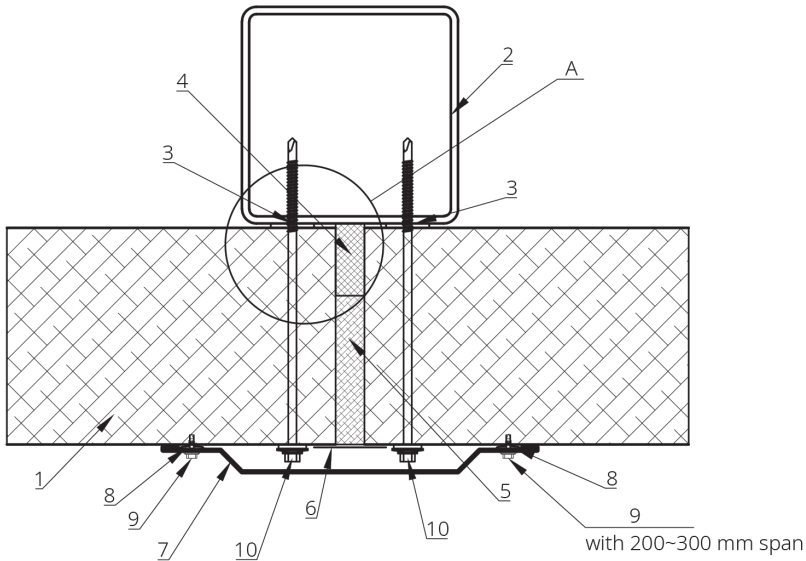

Option 2.  
Concrete wall fastening using the profiled metal

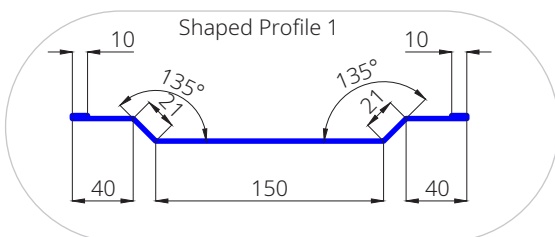
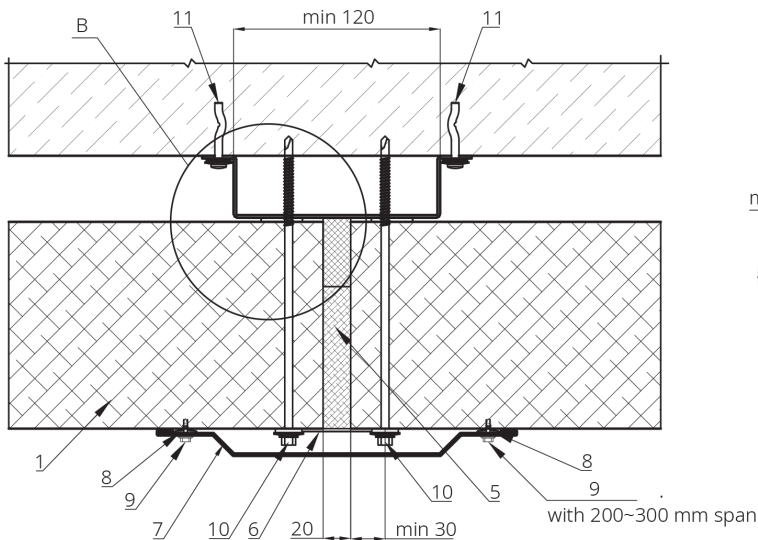

**JOINT 1. VERTICAL JOINT – HORIZONTAL ARRANGEMENT OF THE PANELS**

- |   |  |
|---|--|
| 1. sandwich panel   | 7. shaped element  |
| 2. armed concrete column  | 8. sealing compound or butyl latex sealing tape          |
| 3. expansion gasket   | 9. fastener for fastening shaped elements or blind rivet |
| 4. polyurethane foam  | 10. impact anchor  |
| 5. mineral wool core or lightweight<br>grade fibered glass core | 11. concrete screw                                       |
| 6. sealing tape   |  |

Option 3.  
Fastening to the armed concrete

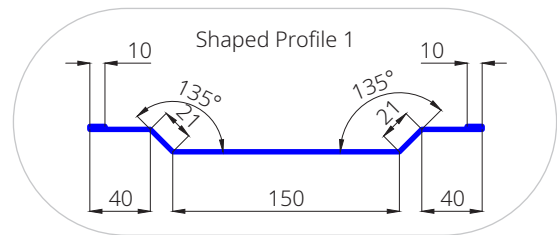
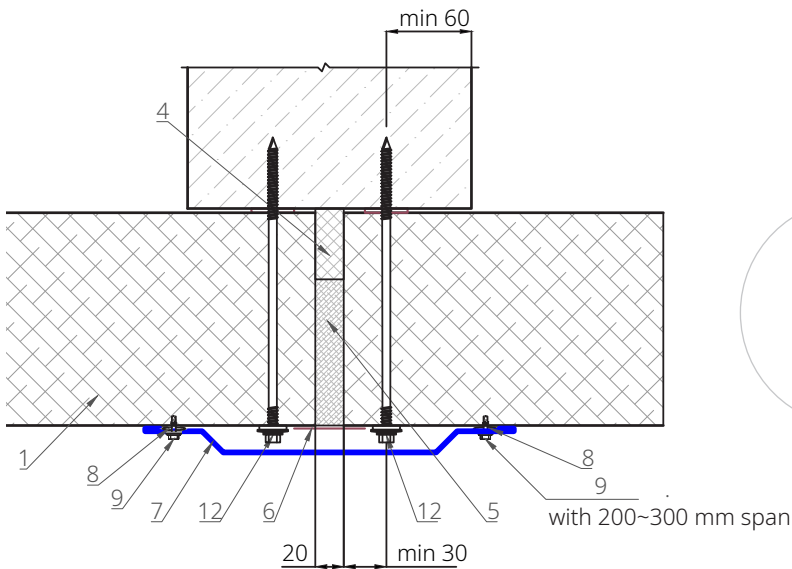

Option 4  
Fastening to the armed concrete using metal corners

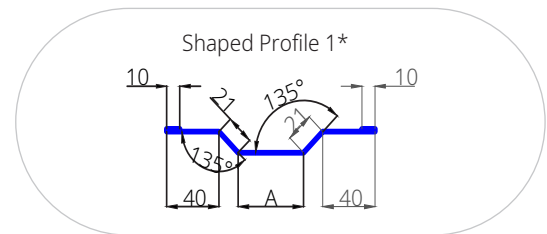
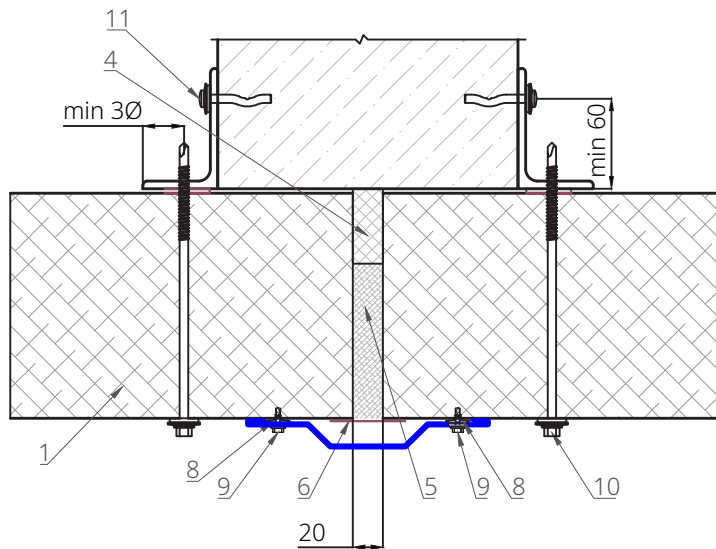



**JOINT 1. VERTICAL JOINT – HORIZONTAL ARRANGEMENT OF THE PANELS**

- |  |   |
|--|---|
| 1. sandwich panel  | 5. sealing tape                                 |
| 2. metal sheet construction                                  | 6. shaped element                               |
| 3. expansion gasket  | 7. sealing compound or butyl latex sealing tape |
| 4. mineral wool core or lightweight grade<br>fiberglass core | 8. blind rivet                                  |
|  | 9. sandwich panels fastener                     |

Option 5.  
Fastening to the metal sheet in the functional joint place

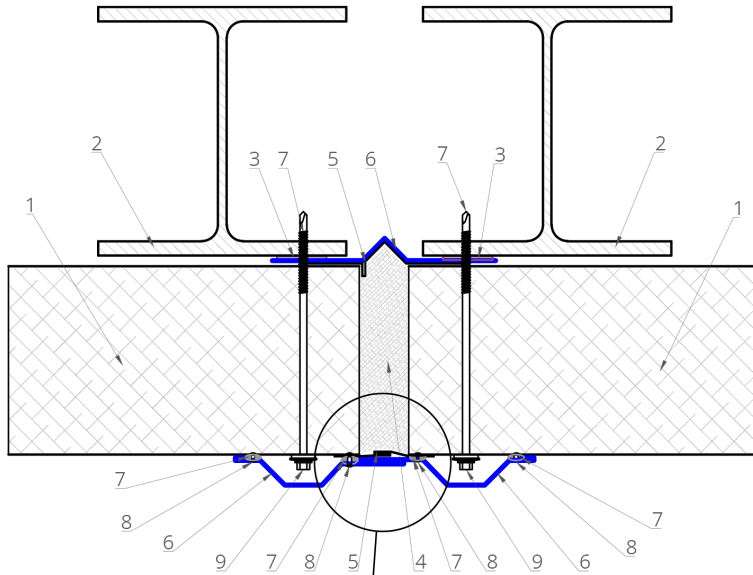

Construction node  
A 3:1 scale

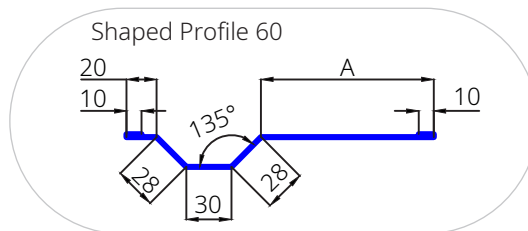
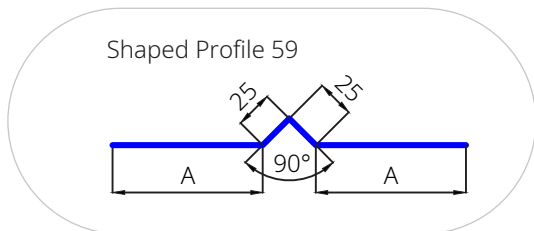
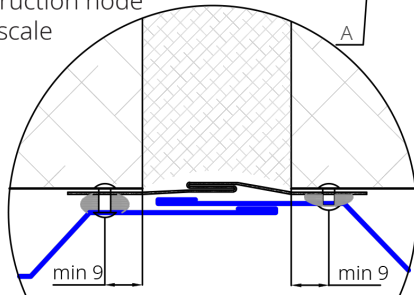

## JOINT 2. VERTICAL CORNER JOINT OF THE WALL SANDWICH PANELS

- |  |  |
|--|--|
| 1. sandwich panel  | 6. shaped element  |
| 2. metal sheet construction                                  | 7. sealing compound or butyl latex sealing tape          |
| 3. expansion gasket  | 8. pop rivet   |
| 4. mineral wool core or lightweight grade<br>fiberglass core | 9. fastener for fastening shaped elements or blind rivet |
| 5. sealing tape  | 10. sandwich panel fastener                              |

Option 1  
Joining to one framework

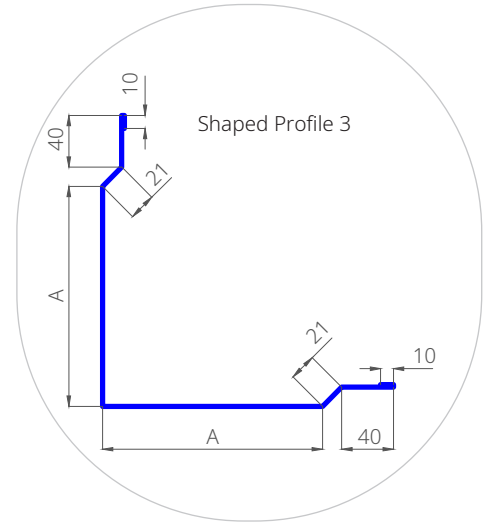
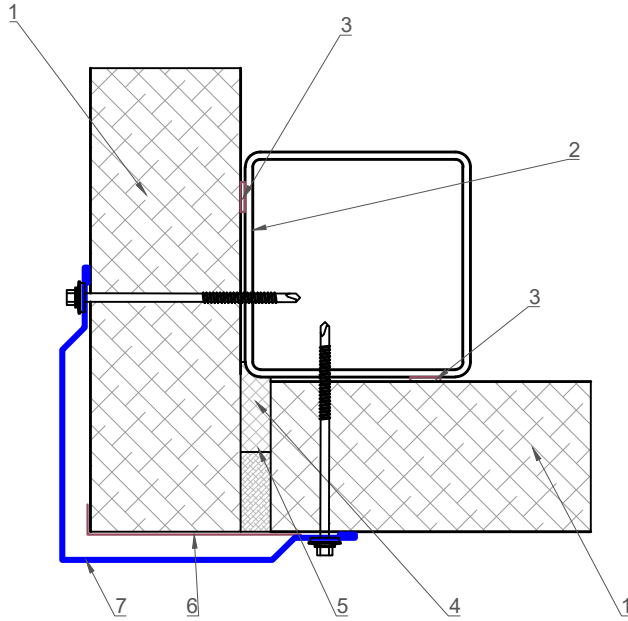

Option 2.  
Joining to 2 frameworks

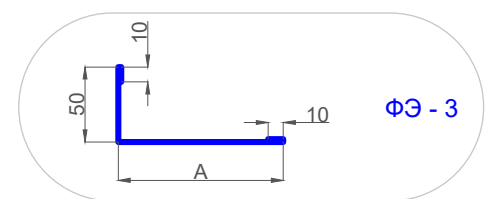
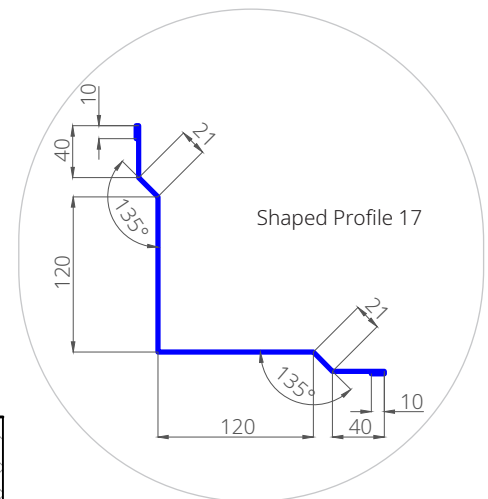
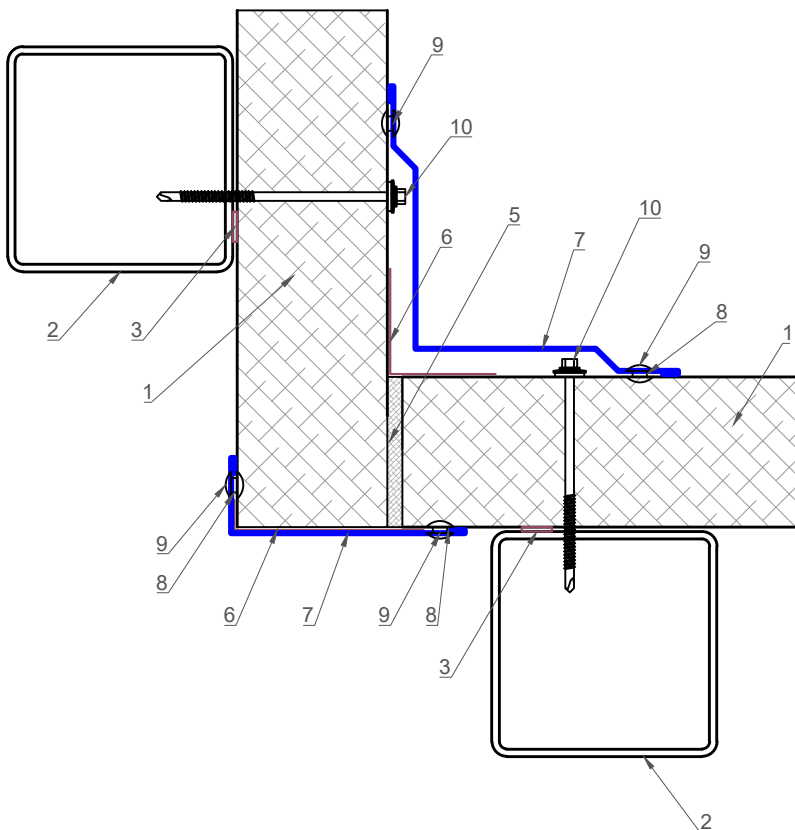

### JOINT 3. JOINT OF THE WALL SANDWICH PANELS TO THE SOLE

- |  |  |
|--|--|
| 1. sandwich panel  | 7. shaped element  |
| 2. sole plate  | 8. sealer or butyl rope                                  |
| 3. waterproofing   | 9. fastener for fastening shaped elements or blind rivet |
| 4. butyl tape  | 10. sandwich panel fastener                              |
| 5. expansion gasket  | 11. impact anchor  |
| 6. mineral wool core or lightweight grade<br>fiberglass core |  |

#### Option 1.

Sole plate modification without heat insulation during horizontal panel arrangement

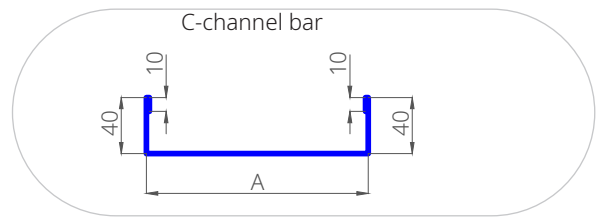
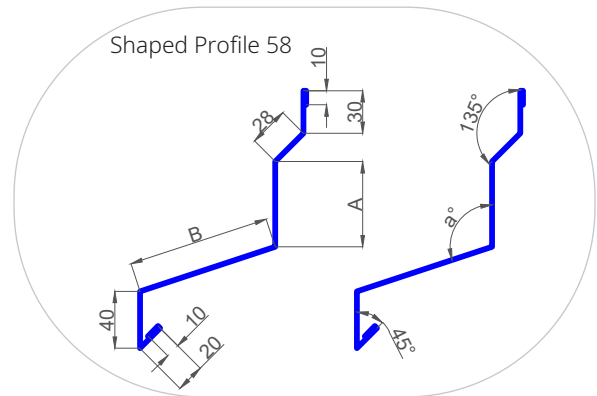
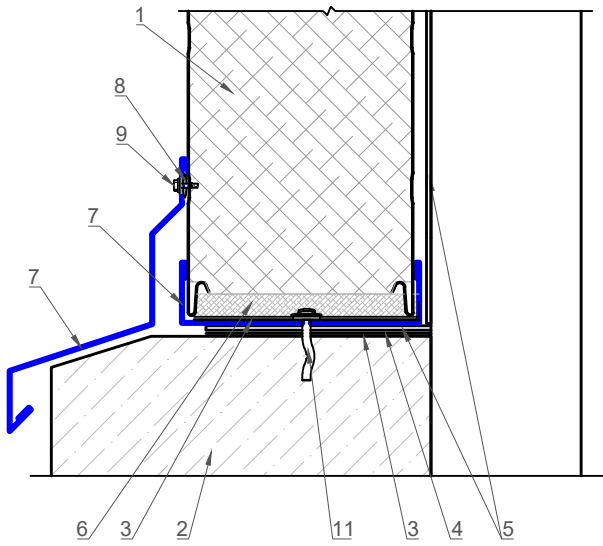

#### Option 2.

Sole plate modification without heat insulation during vertical panel arrangement

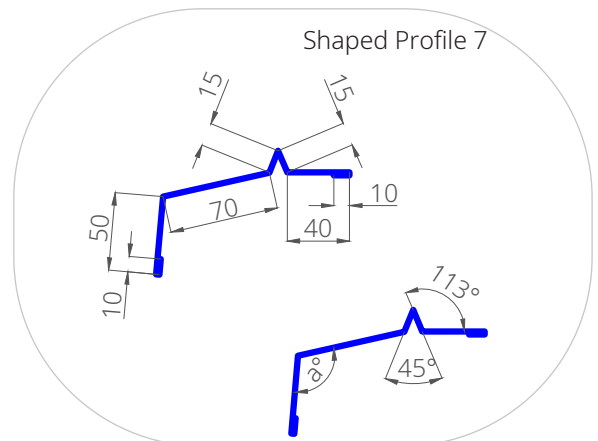
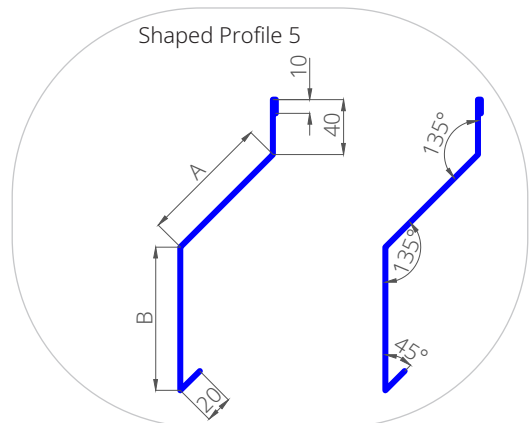
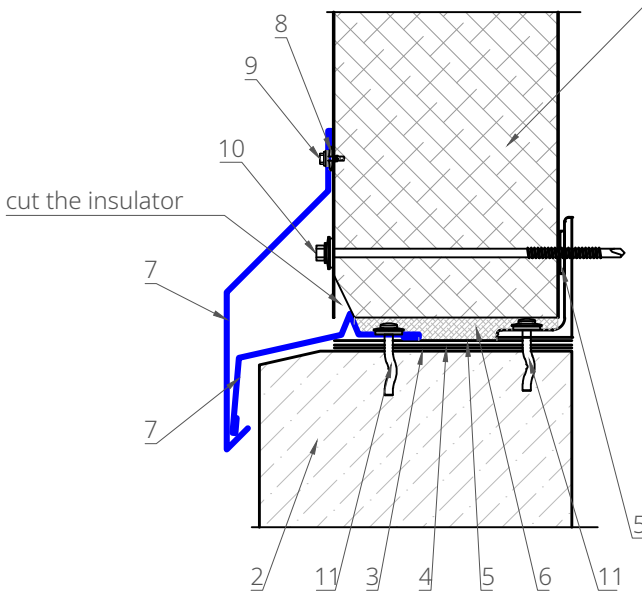

**JOINT 3. WALL PANEL JOINING TO THE SOLE PLATE**

- 1. sandwich panel
- 2. metal sheet construction
- 3. expansion gasket
- 4. mineral wool core or lightweight grade fibered glass core
- 5. sealing tape
- 6. shaped element
- 7. sealing compound or butyl latex sealing tape
- 8. pop rivet
- 9. fastener for fastening shaped elements or blind rivet
- 10. sandwich panel fastener

Option 3.

Sole plate modification with heat insulation

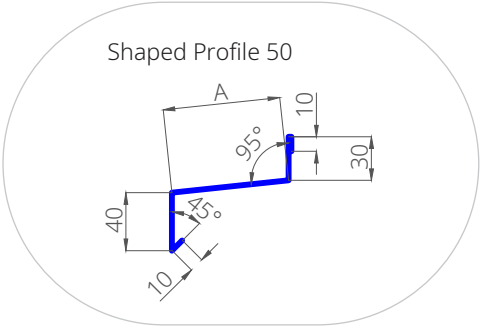
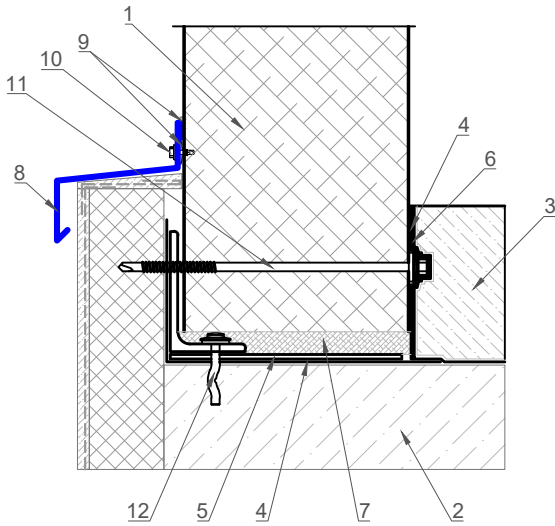

Option 4.

Sole plate modification with heat insulation

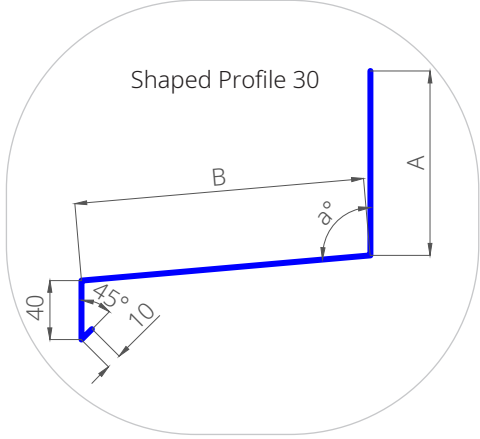
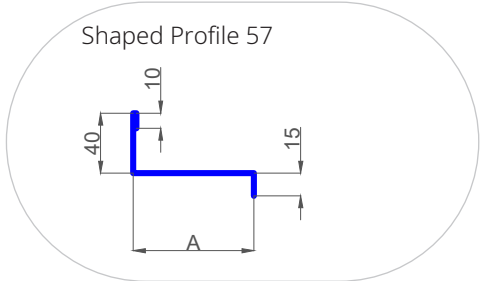
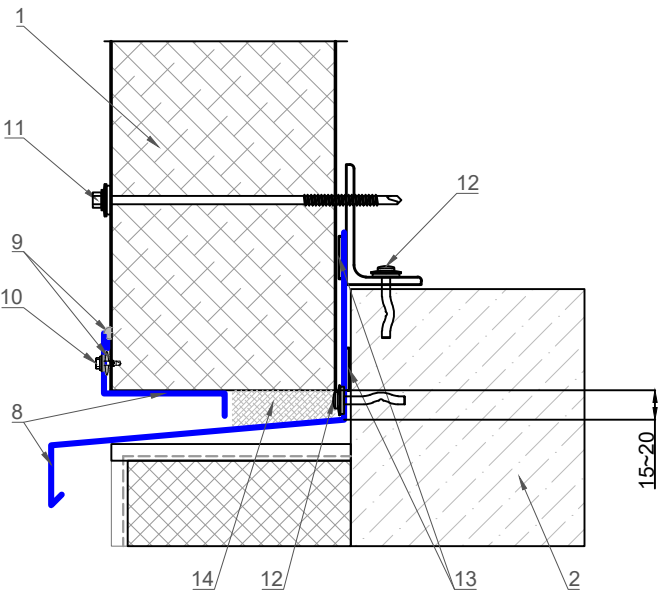

#### JOINT 4. JOINING ROOF SANDWICH PANELS LENGTHWISE

- 1. sandwich panel
- 2. expansion gasket
- 3. purlin

- 4. sandwich panel fastener
- 5. fastener for fastening shaped elements or blind rivet

The beginning of assembly

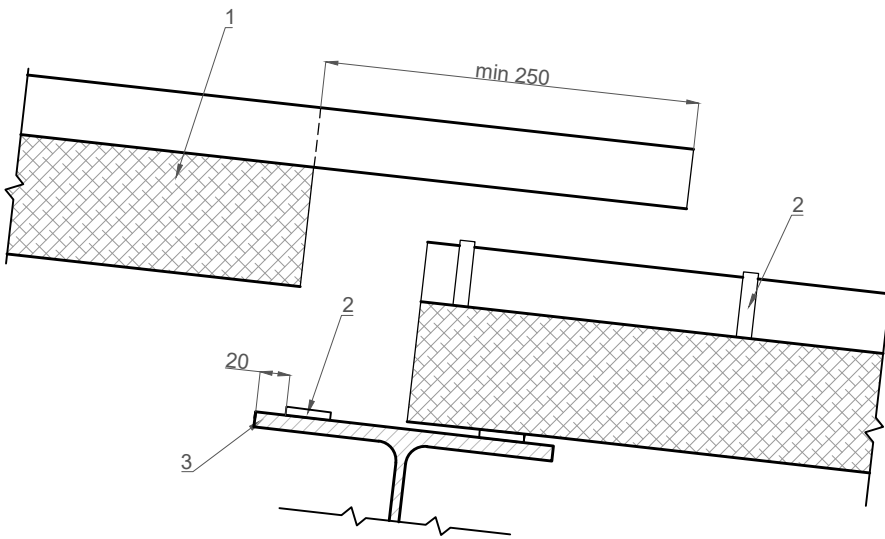

The end of assembly

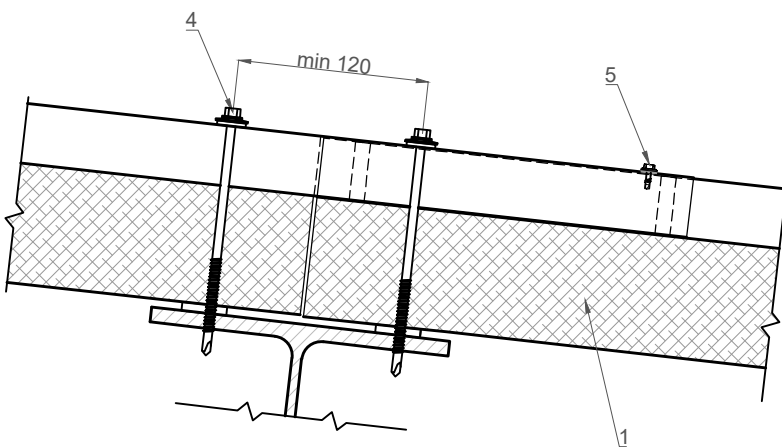

### JOINT 5. SNOW GUARD JOINT

- 1. sandwich panel
- 2. expansion gasket
- 3. purlin
- 4. sandwich panel fastener
- 5. clatex sealing compound or butyl latex sealing tape
- 6. blind rivet or fastener for fastened elements
- 7. shaped element

FE-38 element should be assembled on the roof entry side in Staggered order. The element length must'n exceed 2 m.

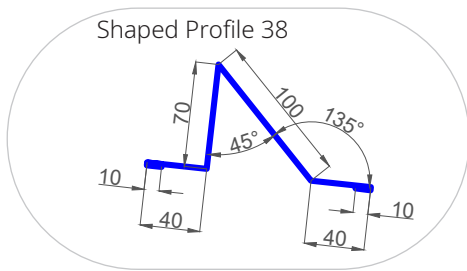
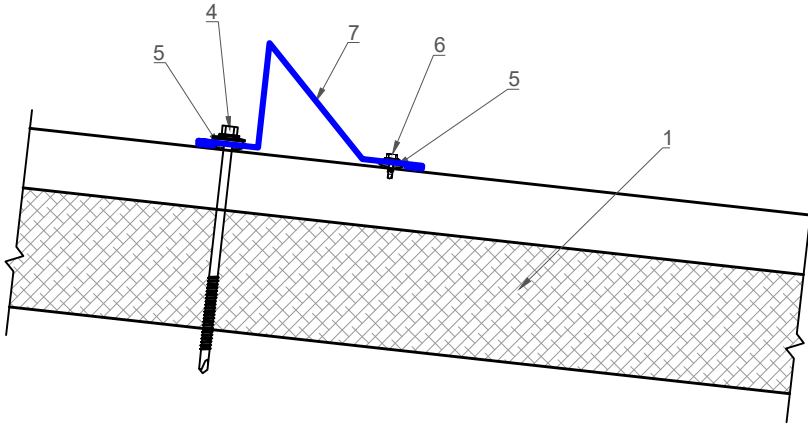

**JOINT 6. ROOF JOINT TO THE LONGITUDINAL WALL.**

- 1. sandwich panel
- 2. ridgy expansion gasket PBK-190 lower
- 3. adhesive sealant
- 4. metal sheets
- 5. expansion gasket
- 6. mineral wool core or lightweight grade fibered glass core
- 7. sandwich panel fastener
- 8. blind rivet or fastener for fastened elements
- 9. latex sealing compound or butyl latex sealing tape
- 10. shaped element

Option 1.  
Roof projection modification

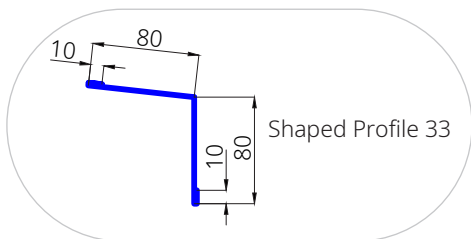
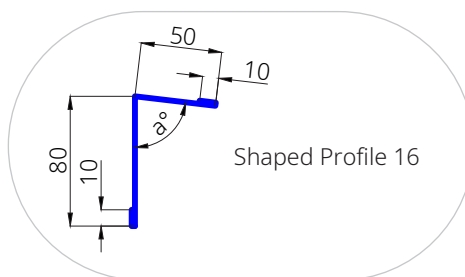
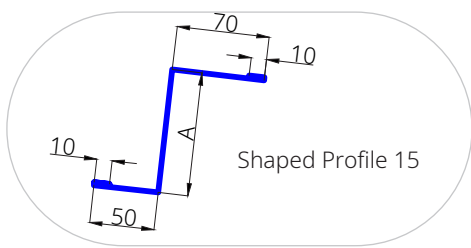
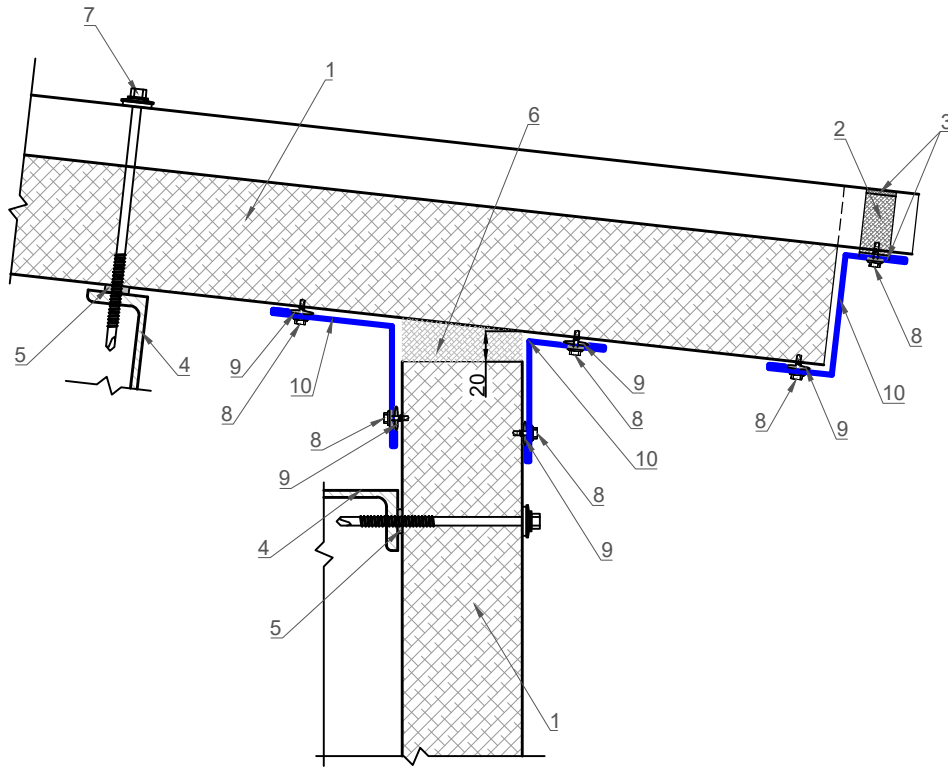

**JOINT 6. ROOF JOINT TO THE LONGITUDINAL WALL.**

- 1. sandwich panel
- 2. ridgy expansion gasket PBK-190 lower
- 3. adhesive sealant
- 4. metal sheets
- 5. expansion gasket
- 6. mineral wool core or lightweight grade fibered glass core

- 7. sandwich panel fastener
- 8. blind rivet or fastener for fastened elements
- 9. latex sealing compound or butyl latex sealing tape
- 10. shaped element

Option 2.  
Roof without the projection modification

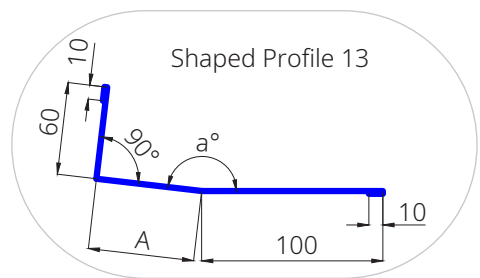
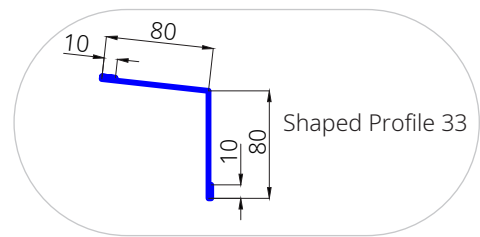
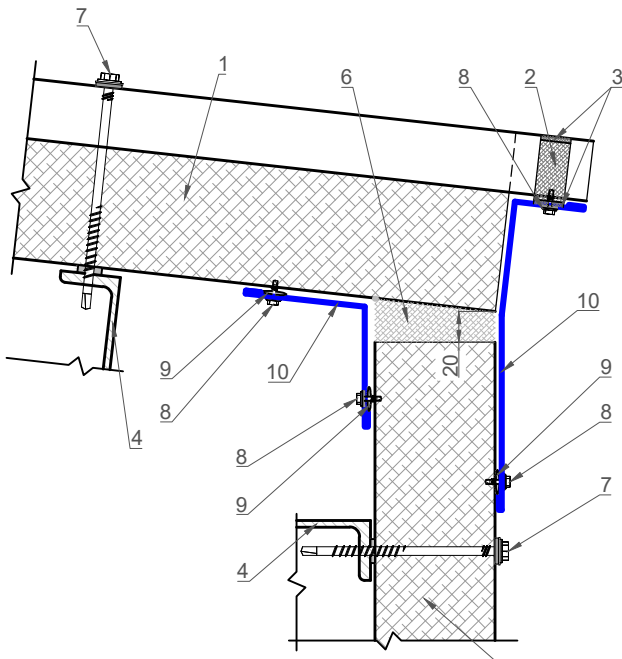
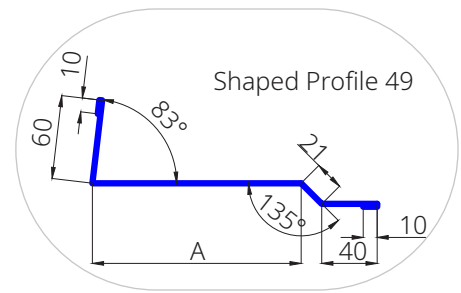
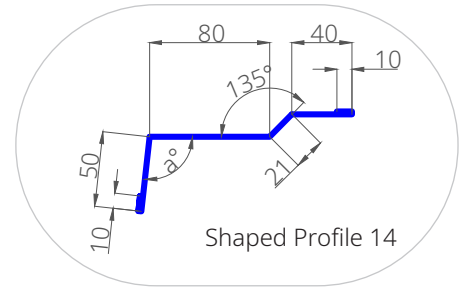
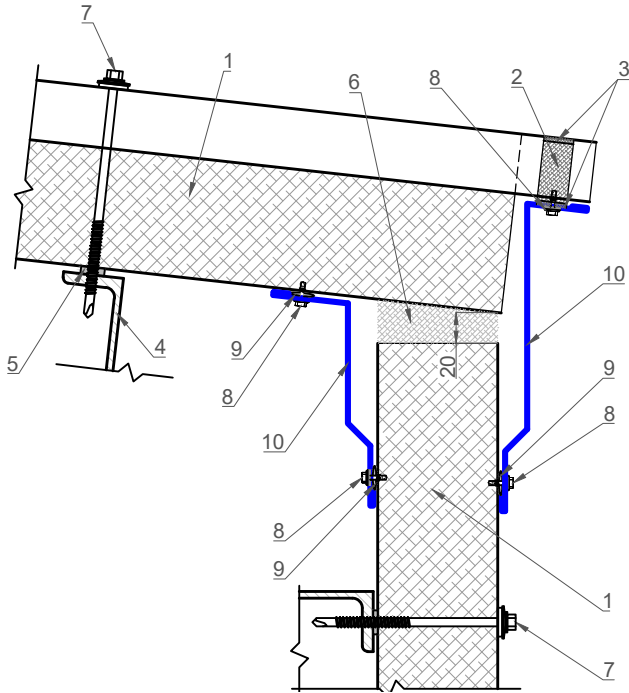



**JOINT 7. ROOF SANDWICH PANELS JOINT IN RIDGY**

- |  |   |
|--|---|
| 1. sandwich panel  | 7. sandwich panel fastener                            |
| 2. ridgy expansion gasket PBK-190/25 lower                   | 8. blind rivet or fastener for fastened elements      |
| 3. adhesive sealant  | 9. latex sealing compound or butyl latex sealing tape |
| 4. purlin  | 10. shaped element                                    |
| 5. expansion gasket  |   |
| 6. mineral wool core or lightweight grade fibered glass core |   |

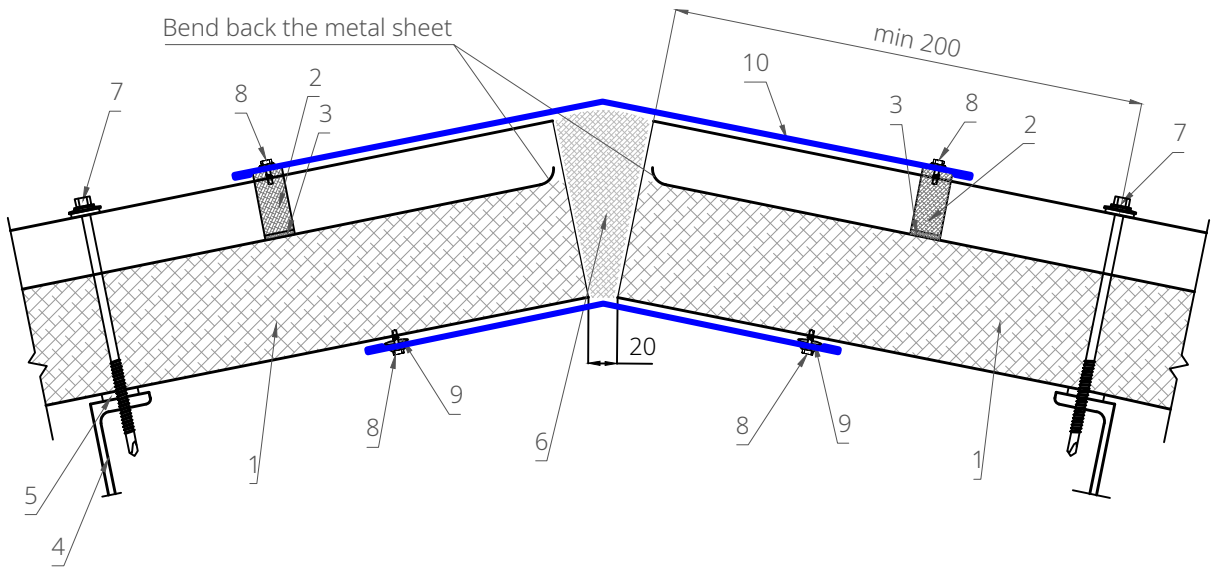

Shaped Profile 19

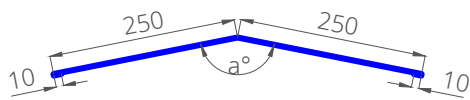

Shaped Profile 20

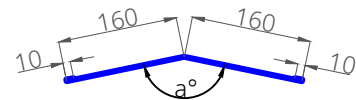

Bend back the metal sheet

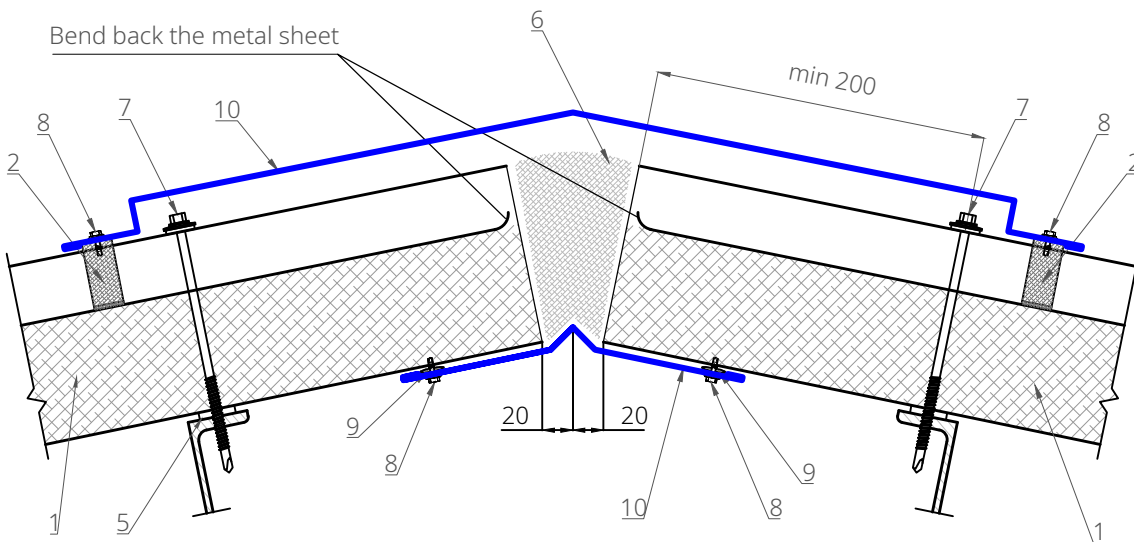

Shaped Profile 28

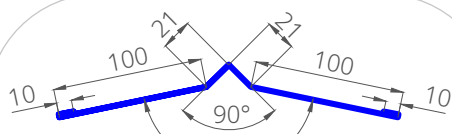

Shaped Profile 53

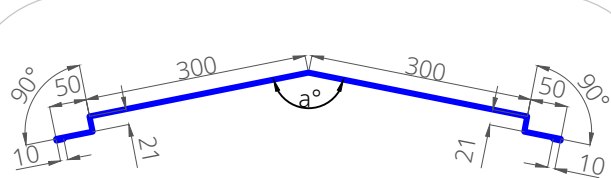

**JOINT 8. MONOPITCH ROOF JOINT TO THE LONGITUDINAL WALL.**

- |  |   |
|--|---|
| 1. sandwich panel  | 7. sandwich panel fastener                            |
| 2. ridgy expansion gasket PBK-190 upper                      | 8. blind rivet or fastener for fastened elements      |
| 3. adhesive sealant  | 9. latex sealing compound or butyl latex sealing tape |
| 4. metal sheets  | 10. shaped element                                    |
| 5. expansion gasket  |   |
| 6. mineral wool core or lightweight grade fibered glass core |   |

Option 1.  
Roof projection modification

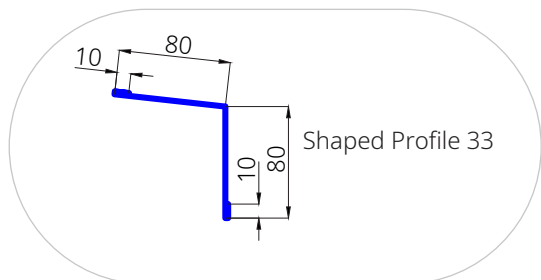
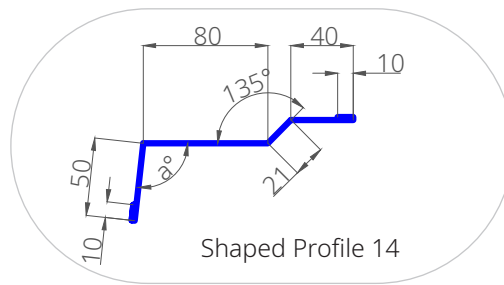
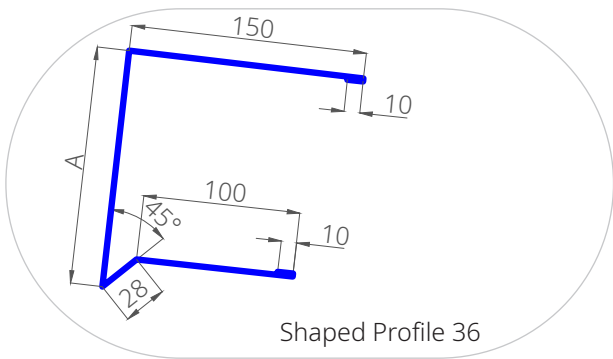
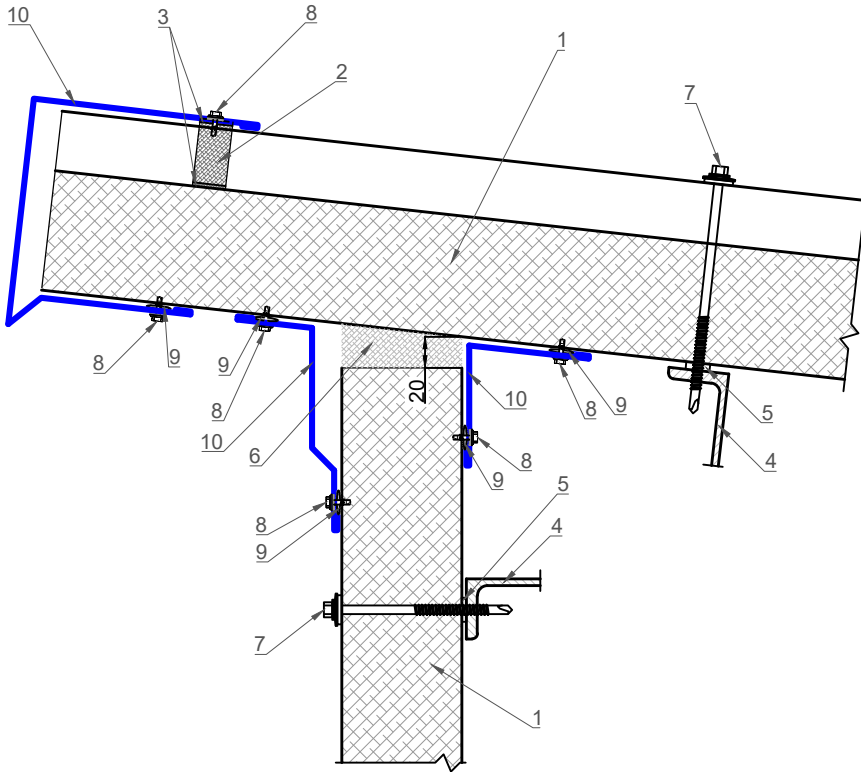

**JOINT 8. MONOPITCH ROOF JOINT TO THE LONGITUDINAL WALL.**

- 1. sandwich panel
- 2. ridgy expansion gasket PBK-190/25 upper
- 3. adhesive sealant
- 4. metal sheets
- 5. expansion gasket
- 6. mineral wool core or lightweight grade fibered glass

- 7. sandwich panel fastener
- 8. blind rivet or fastener for fastened elements
- 9. latex sealing compound or butyl latex sealing tape
- 10. shaped element

Option 2.  
Roof without the projection modification

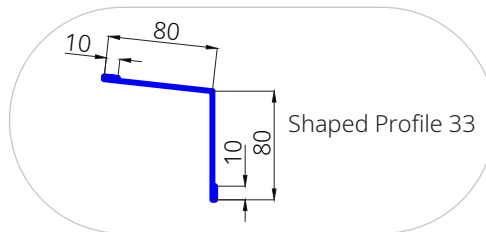
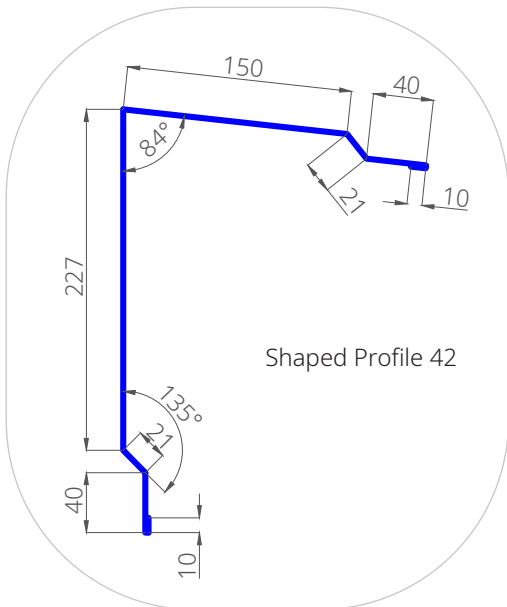
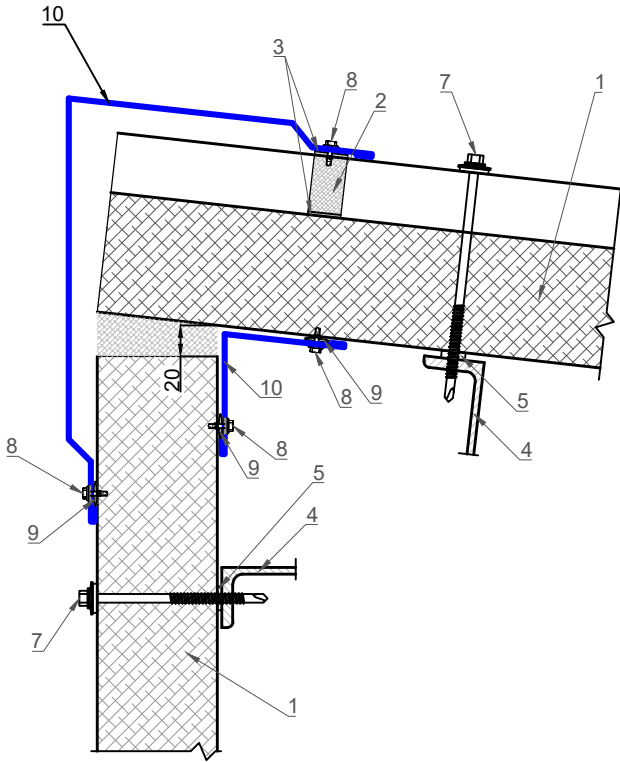

**JOINT 8. MONOPITCH ROOF JOINT TO THE LONGITUDINAL WALL**

- |  |  |
|--|--|
| 1. sandwich panel  | 7. sandwich panel fastener                             |
| 2. ridgy expansion gasket PBK-190/25 upper                   | 8. blind rivet or fastener for fastened elements       |
| 3. adhesive sealant  | 9. clatex sealing compound or butyl latex sealing tape |
| 4. metal sheets  | 10. shaped element                                     |
| 5. expansion gasket  | 11. polymer cold-setting mastic                        |
| 6. mineral wool core or lightweight grade fibered glass core |  |

Option 3  
Roof with guard railing modification

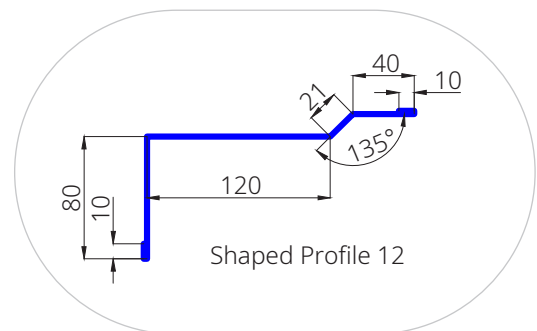
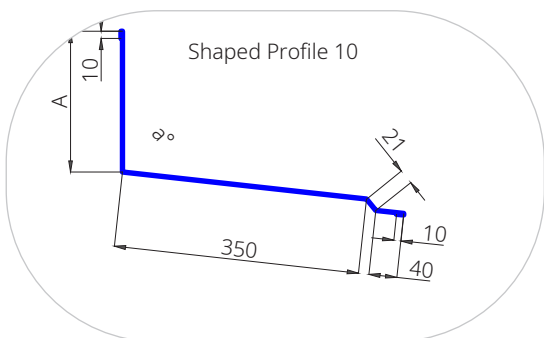
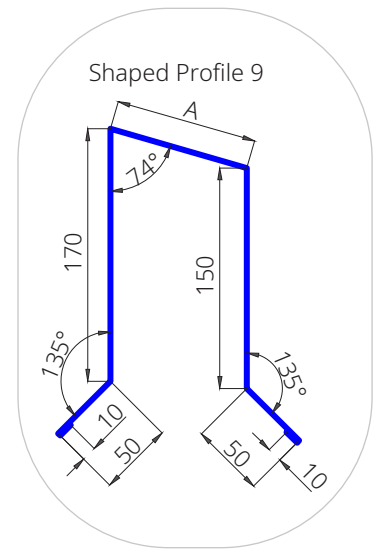
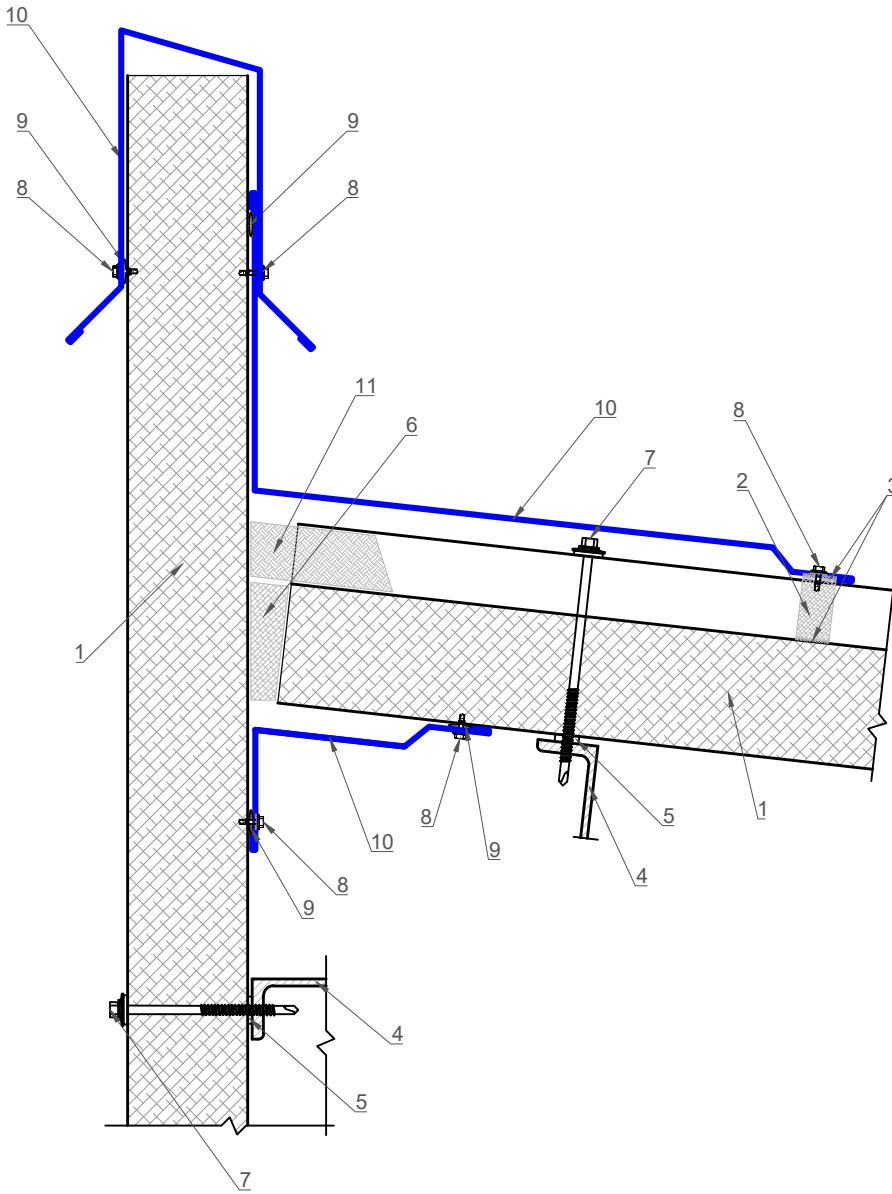

**JOINT 9. ROOF JOINT TO THE EXISTING LONGITUDINAL WALL.**

- 1. sandwich panel
- 2. ridgy expansion gasket PBK-190/25 upper
- 3. adhesive sealant
- 4. metal sheets
- 5. expansion gasket
- 6. mineral wool core or lightweight grade fibered glass core

- 7. sandwich panel fastener
- 8. blind rivet or fastener for fastened elements
- 9. latex sealing compound or butyl latex sealing tape
- 10. shaped element
- 11. polymer cold-setting mastic
- 12. impact anchor

Option 1.  
Joining to the concrete or brick roof

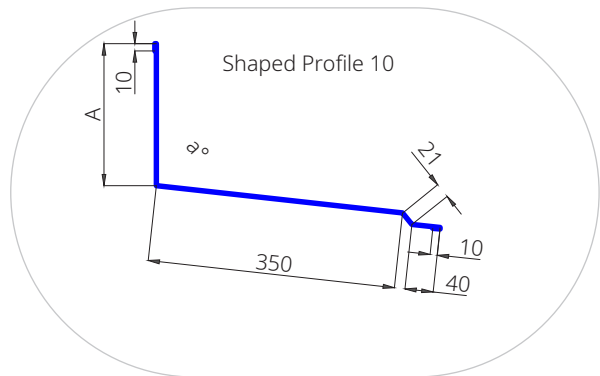
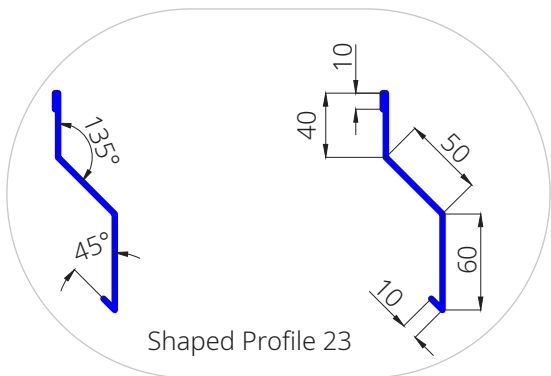
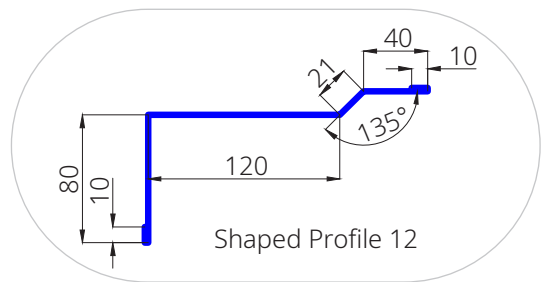
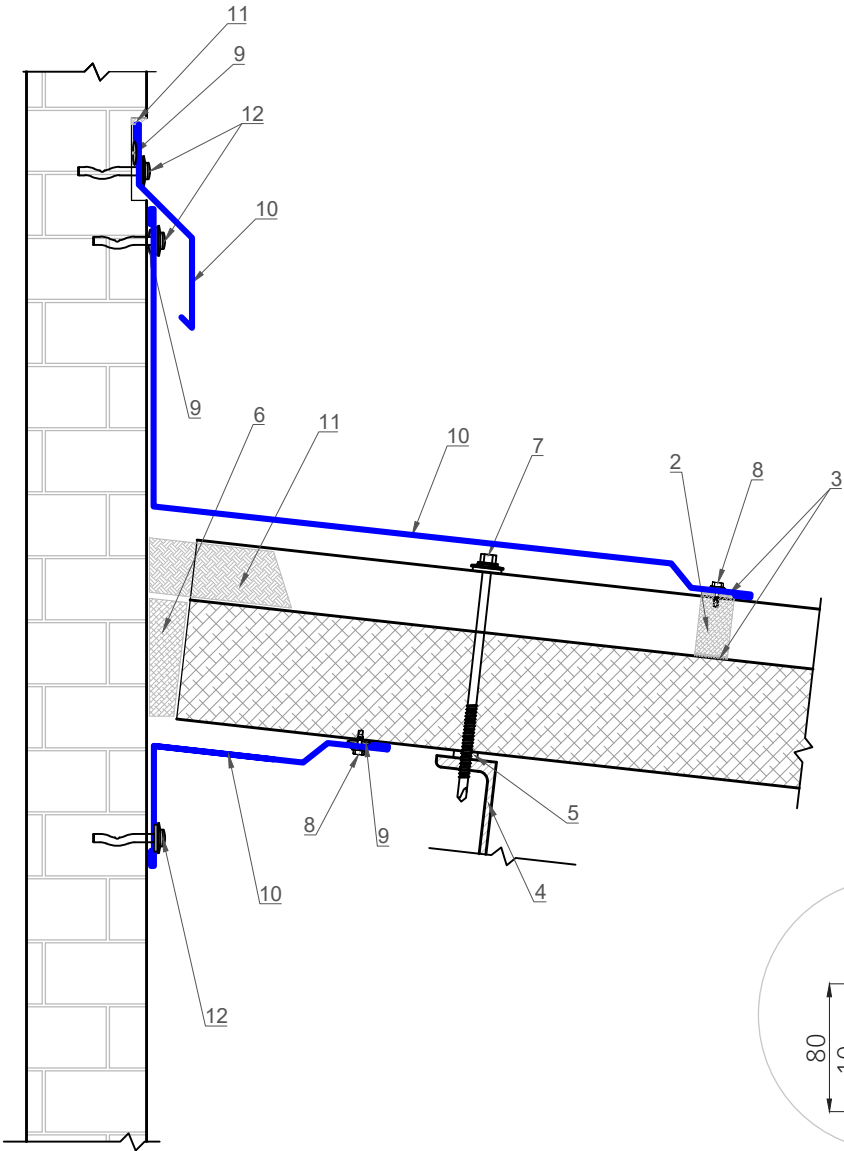

**JOINT 9. ROOF JOINT TO THE EXISTING LONGITUDINAL WALL.**

- |   |   |
|---|---|
| 1. sandwich panel   | 7. sandwich panel fastener                            |
| 2. ridged expansion gasket PBK-190/25 upper                 | 8. blind rivet or fastener for fastened elements      |
| 3. adhesive sealant   | 9. latex sealing compound or butyl latex sealing tape |
| 4. metal sheets   | 10. shaped element                                    |
| 5. expansion gasket   | 11. polymer cold-setting mastic                       |
| 6. mineral wool core or lightweight grade fibred glass core |   |

Option 2.  
Joining to the sandwich panels wall

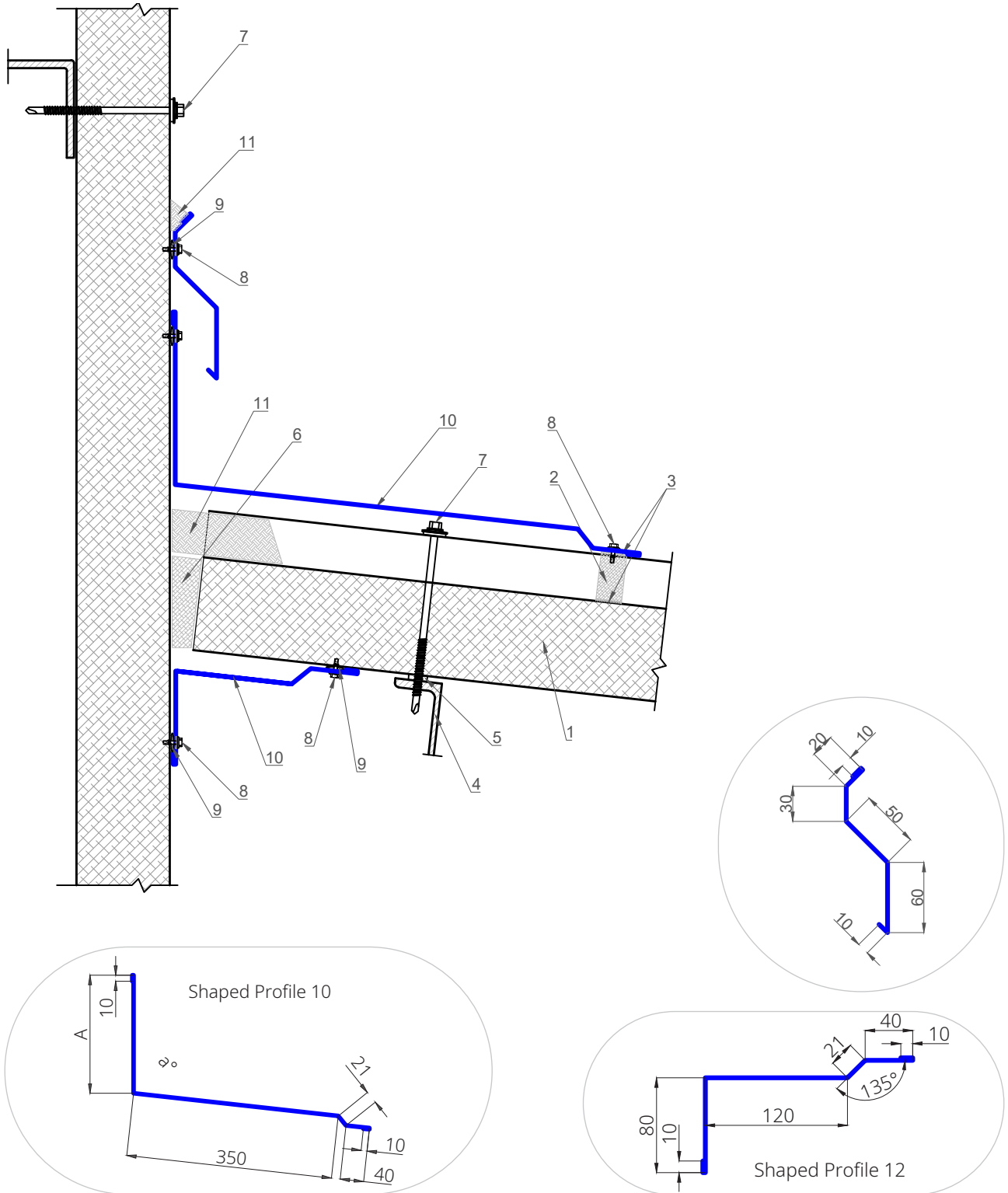

## JOINT 10. JOINING OF ROOF TO THE END WALL

1. sandwich panel
2. metal sheets
3. expansion gasket
4. sealing tape
5. mineral wool core or lightweight grade fibred glass core
6. sandwich panel fastener
7. blind rivet or fastener for fastened elements
8. latex sealing compound or butyl latex sealing tape
9. shaped element

Option 1.  
Roofing with rejection, without undercut

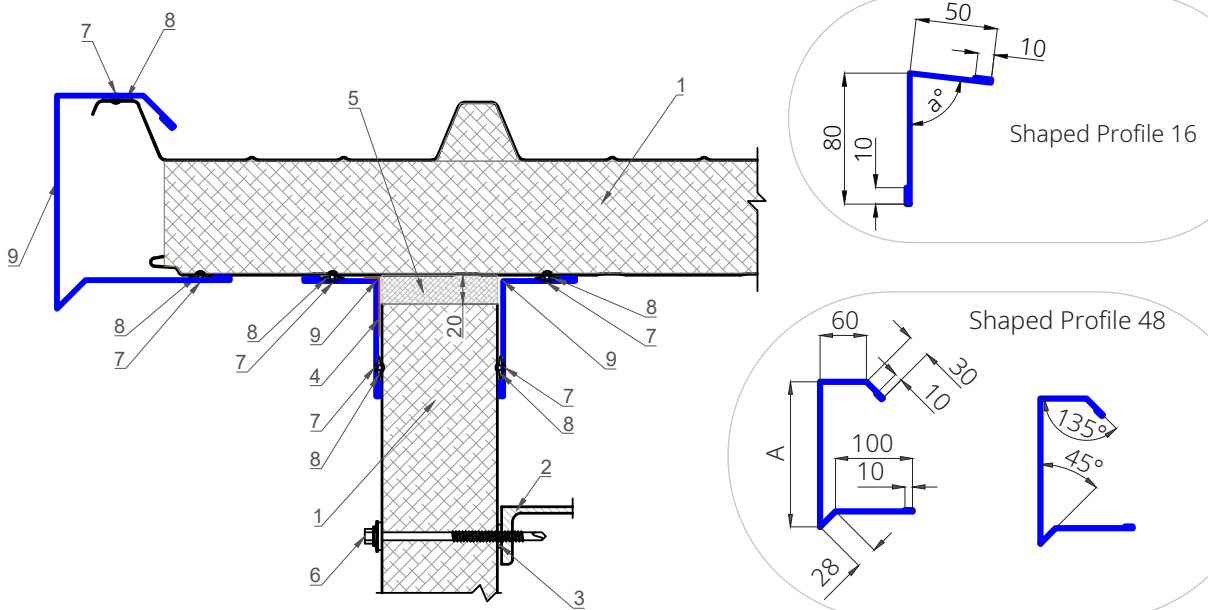

Option 2  
Roofing with rejection, with undercut

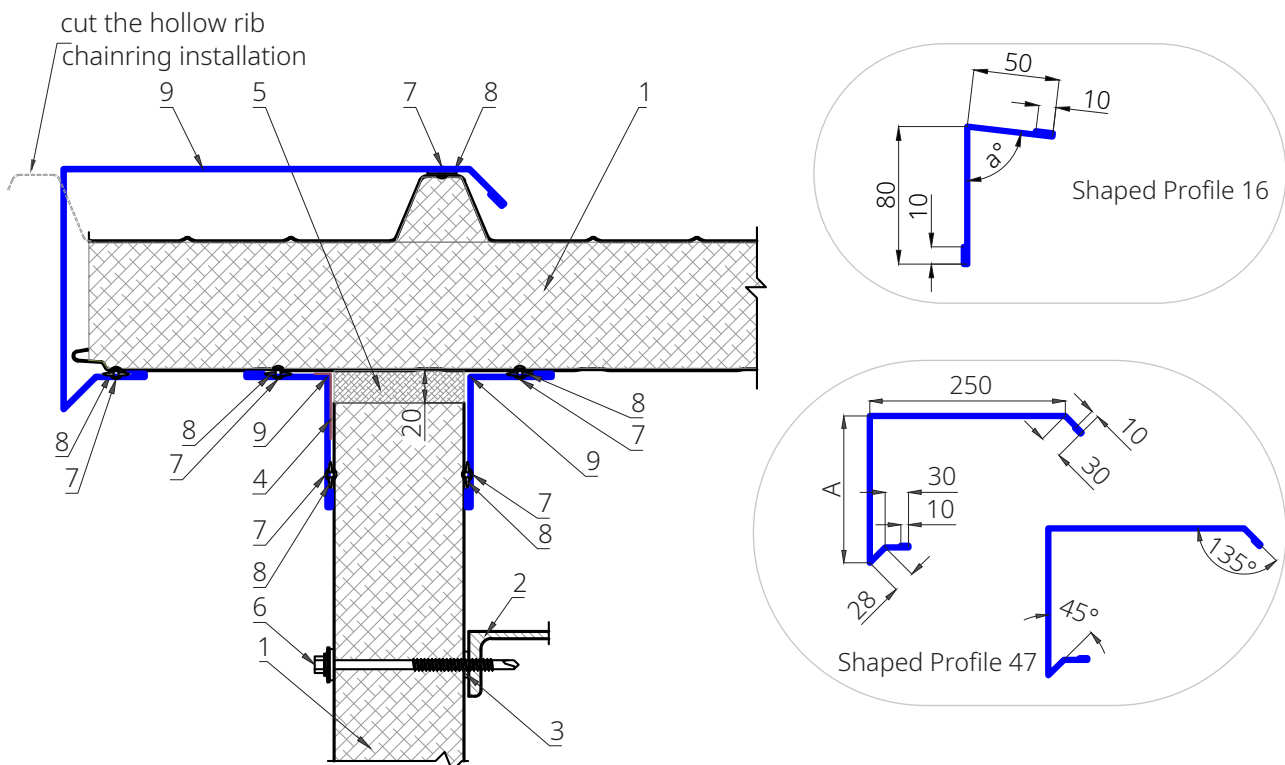

**JOINT 10. JOINING OF ROOF TO THE END WALL**

- 1. sandwich panel
- 2. metal sheets
- 3. expansion gasket
- 4. assembly foam
- 5. mineral wool core or lightweight grade fibred glass core

- 6. sandwich panel fastener
- 7. blind rivet or fastener for fastened elements
- 8. latex sealing compound or butyl latex sealing tape
- 9. shaped element

Option 3.  
Roofing without rejection, without undercut

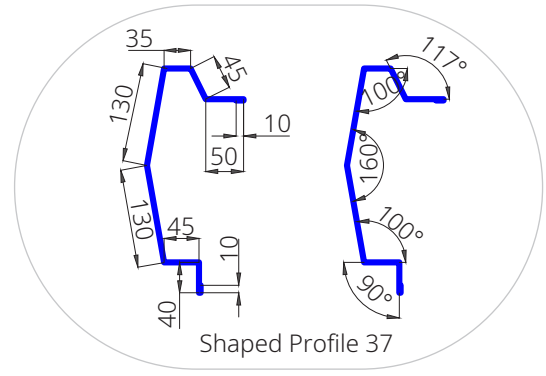
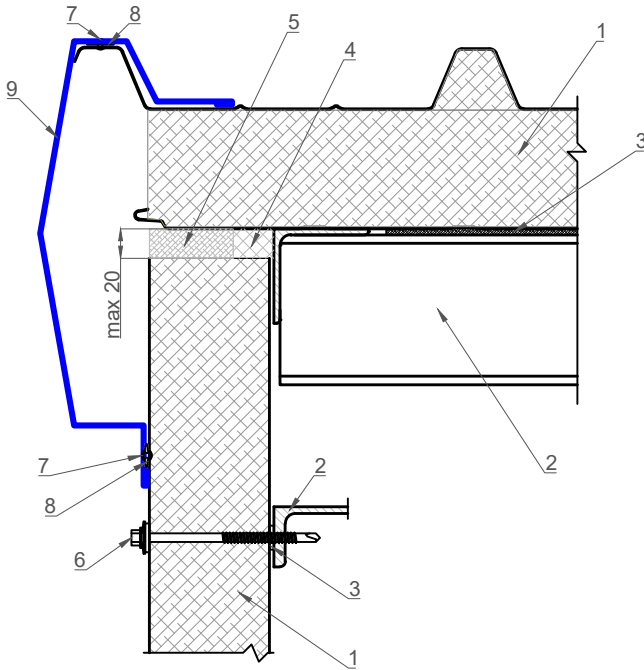

- 4

Option 4.  
Roofing without rejection, with undercut

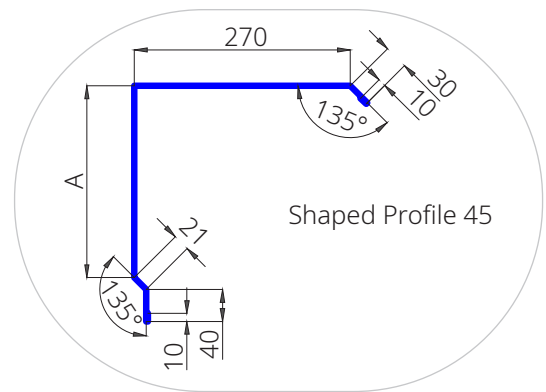
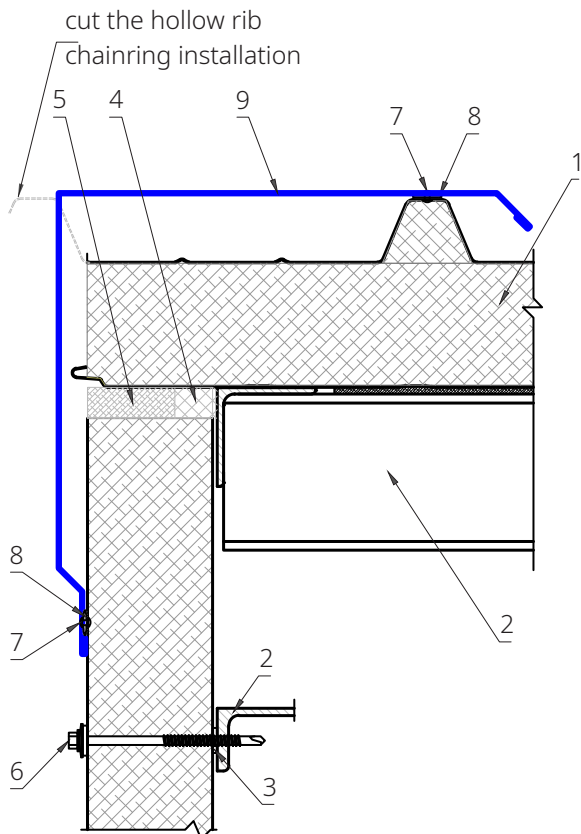



**JOINT 10. JOINING OF ROOF TO THE END WALL**

- |  |   |
|--|---|
| 1. sandwich panel  | 6. blind rivet or fastener for fastened elements      |
| 2. metal sheets  | 7. latex sealing compound or butyl latex sealing tape |
| 3. expansion gasket  | 8. shaped element                                     |
| 4. mineral wool core or lightweight grad fibred glass core | 9. polymer cold-setting mastic                        |
| 5. sandwich panel fastener                                 |   |

Option 5.  
Roofing with guard railing modification

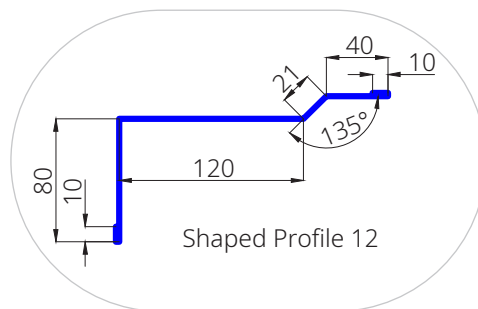
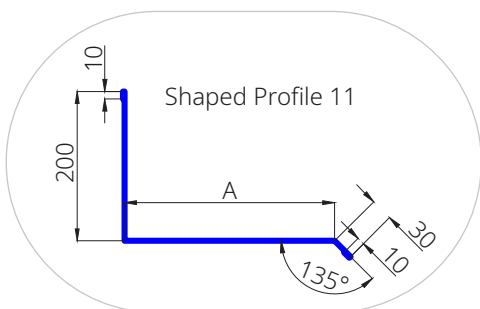
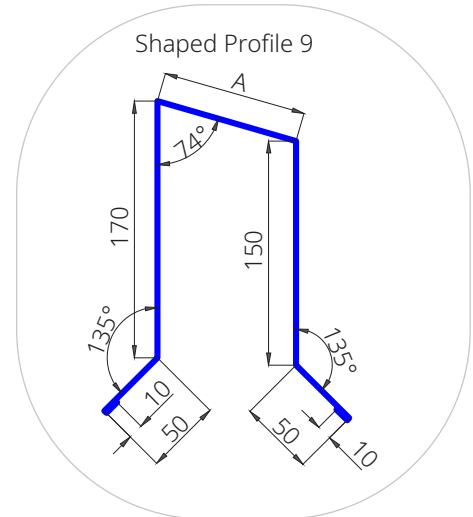
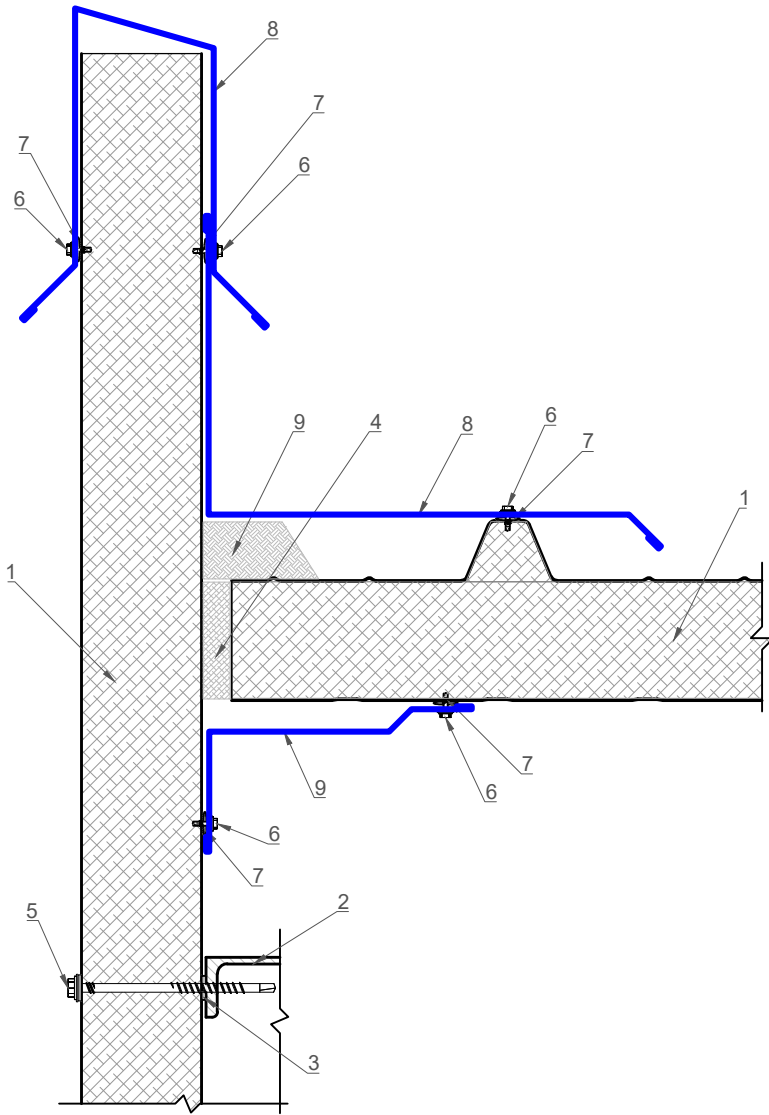

**JOINT 11. JOINING ROOF TO AN EXISTING END WALL**

- 1. sandwich panel
- 2. impact anchor
- 3. mineral wool core or lightweight grade fibred glass core

- 4. blind rivet or fastener for fastened elements
- 5. latex sealing compound or butyl latex sealing tape
- 6. shaped element
- 7. polymer cold-setting mastic

Option 1.  
Joining to a concrete or brick wall

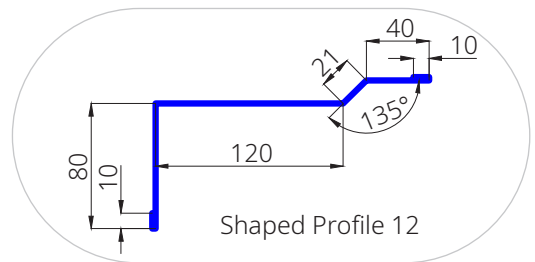
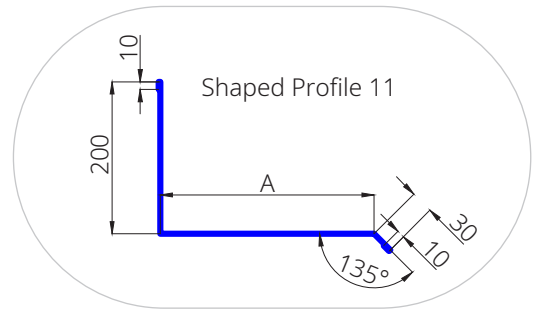
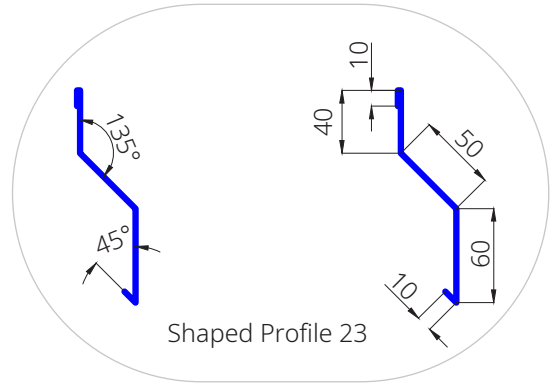
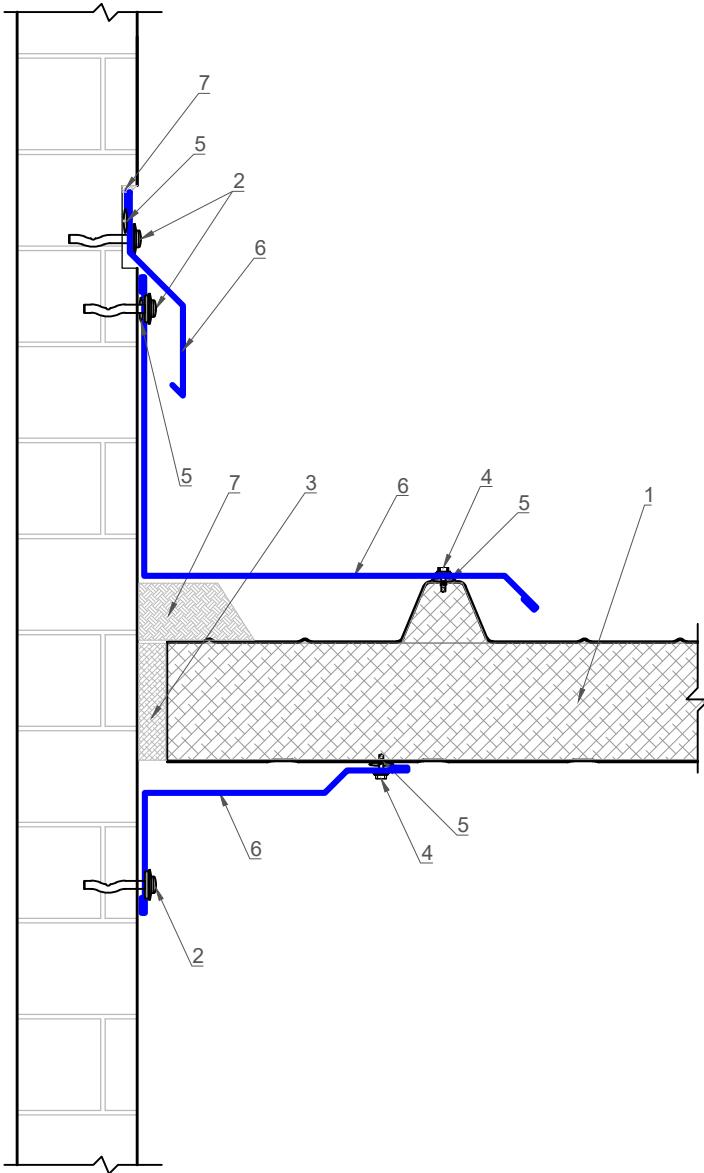

**JOINT 11. JOINING ROOF TO AN EXISTING END WALL**

- 1. sandwich panel
- 2. metal sheets
- 3. expansion gasket
- 4. mineral wool core or lightweight grade fibred glass core.
- 5. sandwich panel fastener

- 6. blind rivet or fastener for fastened elements
- 7. latex sealing compound or butyl latex sealing tape
- 8. shaped element
- 9. polymer cold-setting mastic

Option 2.

Joining to a sandwich panel wall

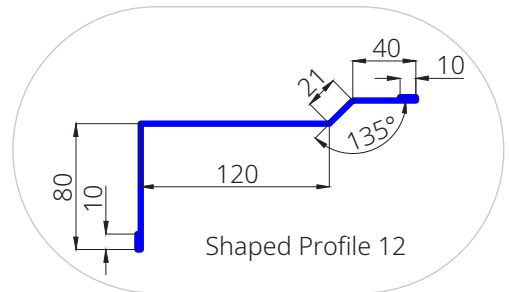
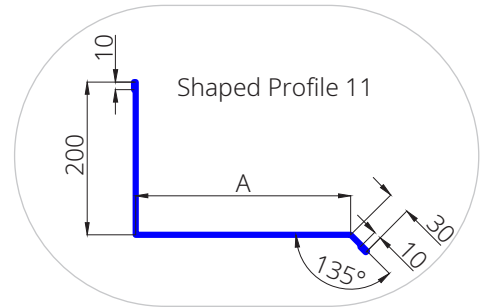
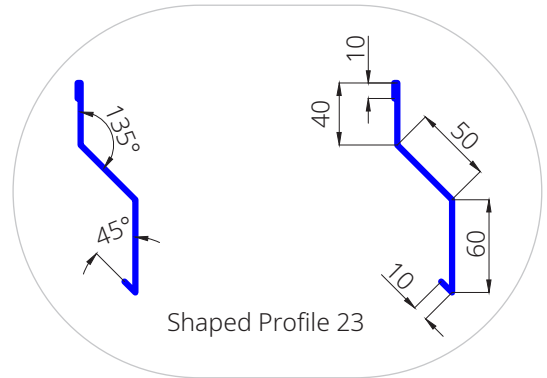
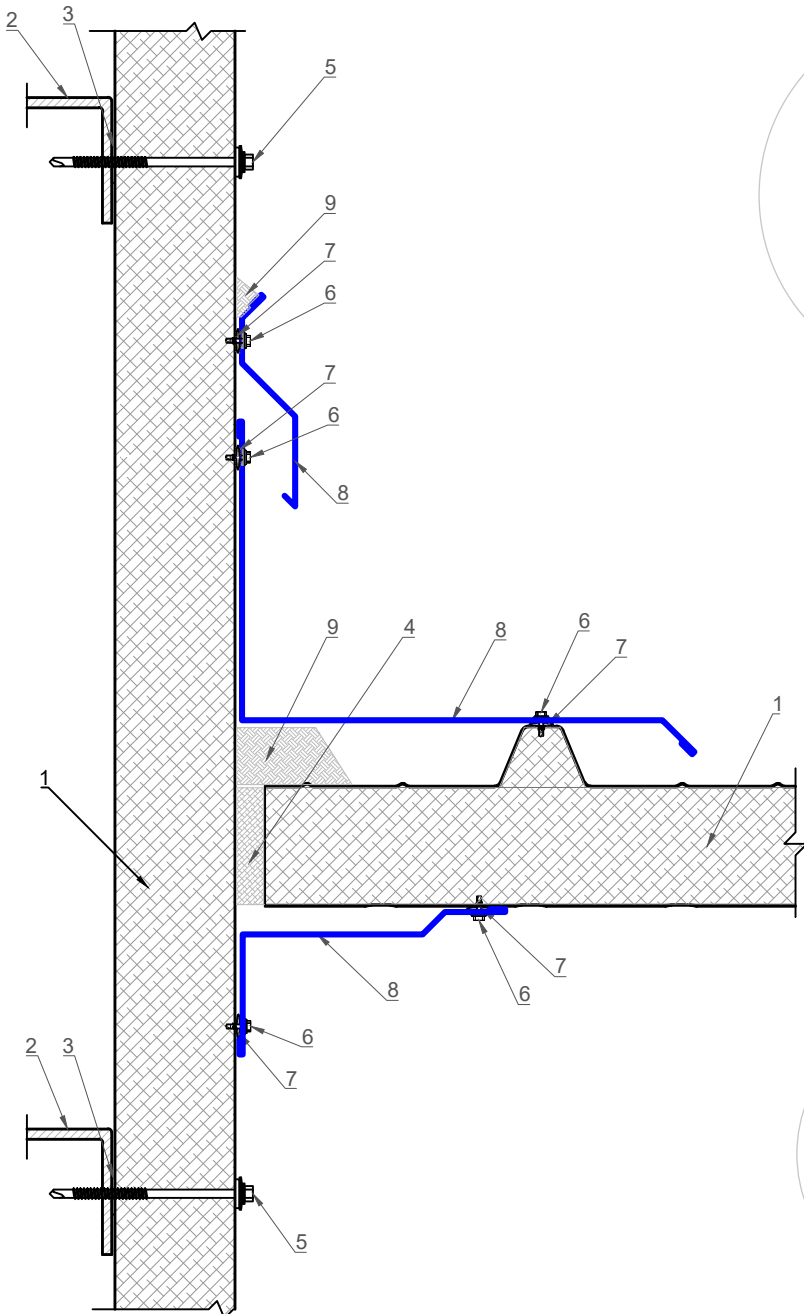

## JOINT 12. WINDOW FRAMING

1. sandwich panel
2. window
3. metal frame
4. sealing foam

5. sealing tape
6. silicon sealing foam
7. self-drilling screw for insulated panels
8. self-drilling screw for flashings

Option 1.

Window inside sandwich panel, installation to structural steel beam

Horizontal view

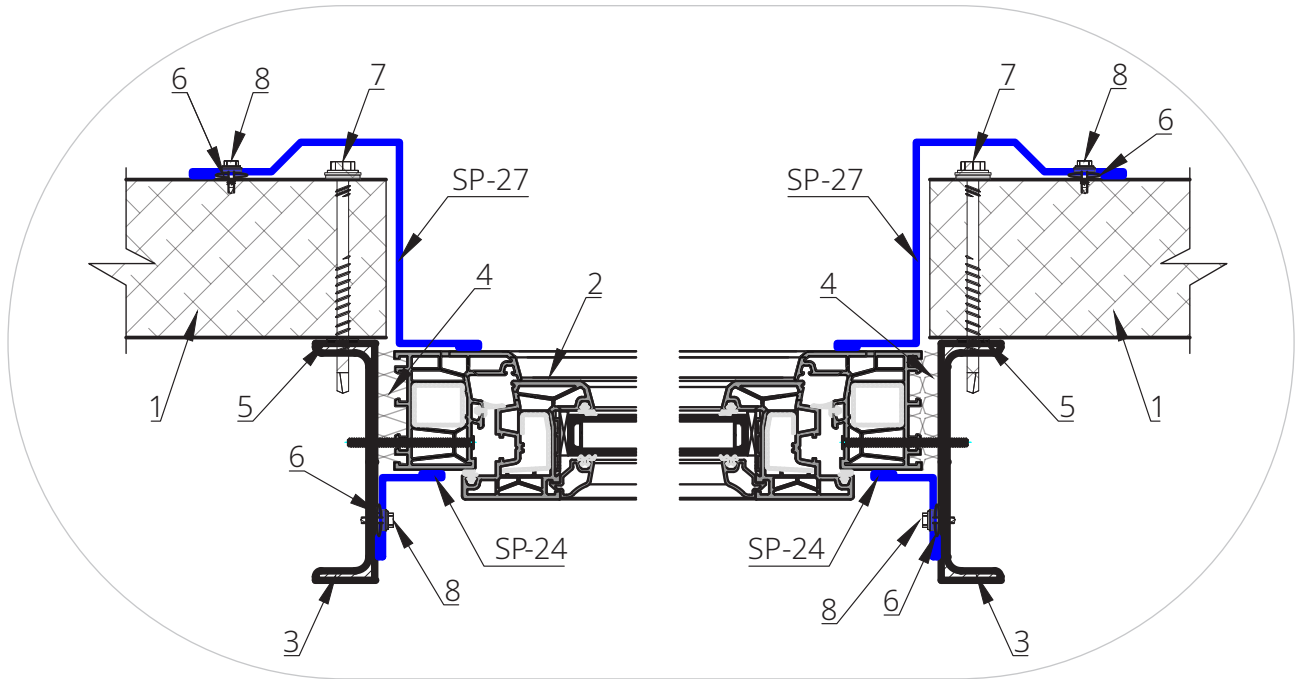

Shaped Profile 23

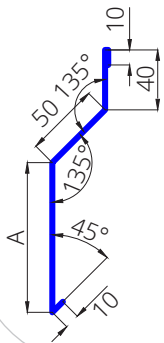

Shaped Profile 24

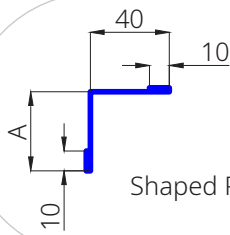

Shaped Profile 27

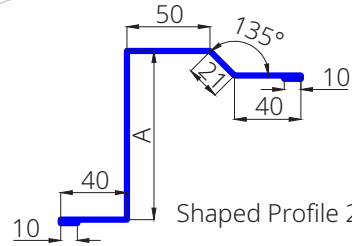

Shaped Profile 30

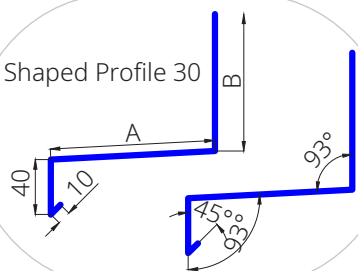

Shaped Profile 50

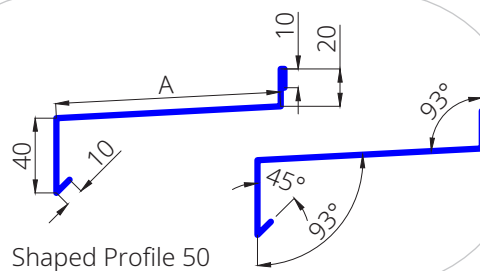

**JOINT 12. WINDOW FRAMING**

- 1. sandwich panell
- 2. window
- 3. metal frame
- 4. sealing foam

- 5. sealing tape
- 6. silicon sealing foam
- 7. self-drilling screw for insulated panels
- 8. self-drilling screw for flashings

Option 1.  
Window inside sandwich panel, installation to structural steel beam  
Vertical view

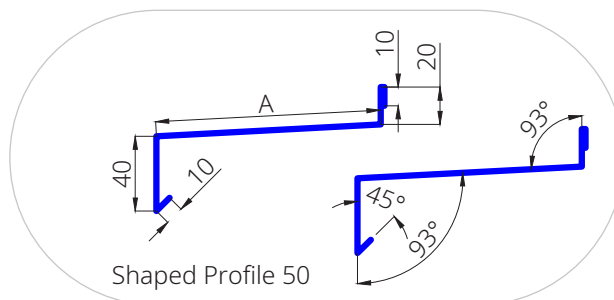
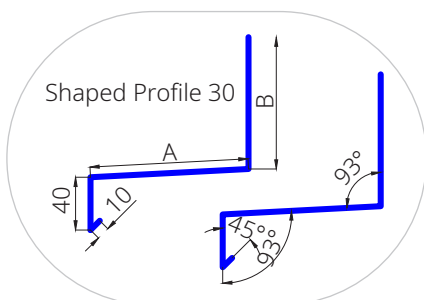
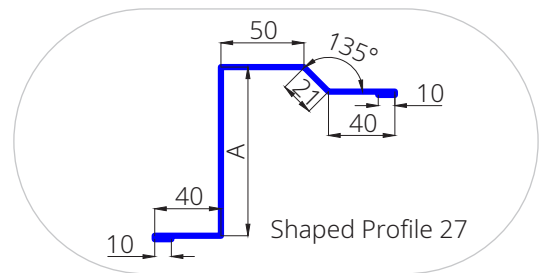
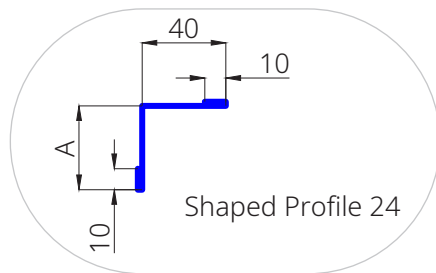
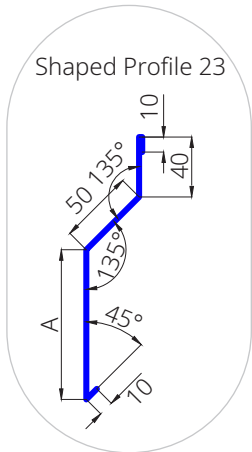
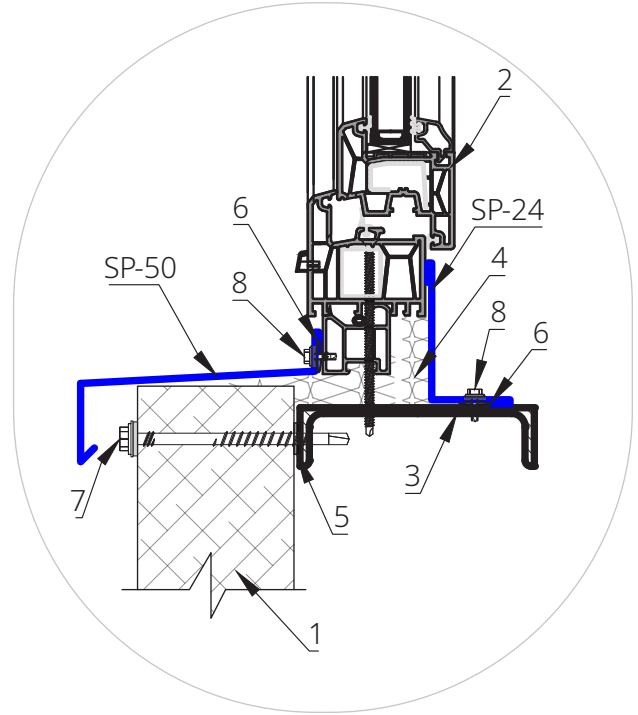
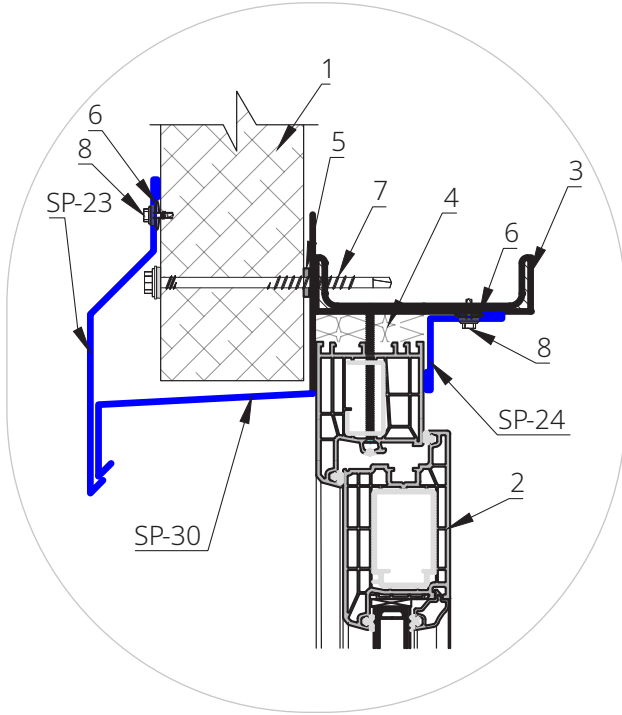

## JOINT 12. WINDOW FRAMING

1. sandwich panell
2. window
3. metal frame
4. sealing foam

5. sealing tape
6. silicon sealing foam
7. self-drilling screw for insulated panels
8. self-drilling screw for flashings

Option 2.

Window inside sandwich panel, installation to sandwich panel flat on the inside.

Horizontal view

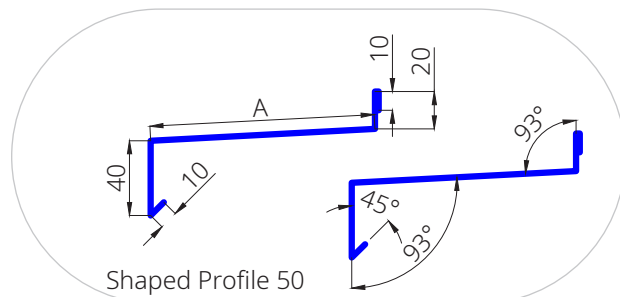
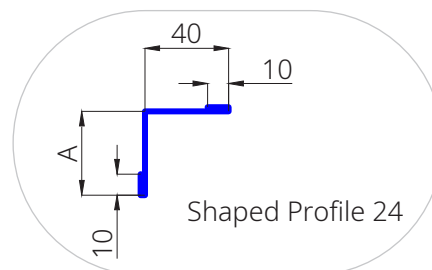
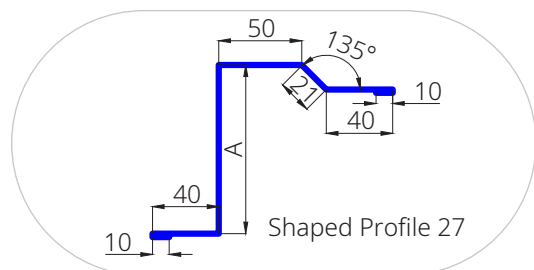
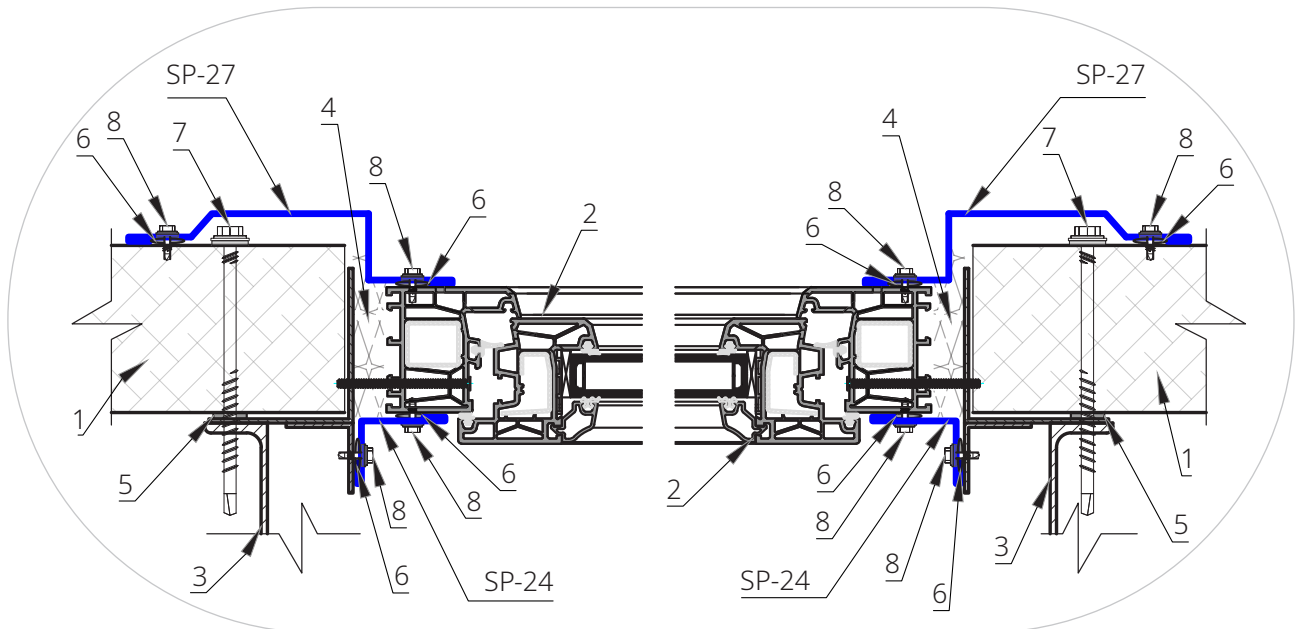

## JOINT 12. WINDOW FRAMING

1. sandwich panell
2. window
3. metal frame
4. sealing foam

5. sealing tape
6. silicon sealing foam
7. self-drilling screw for insulated panels
8. self-drilling screw for flashings

Option 2.

Window inside sandwich panel, installation to sandwich panel flat on the inside.

Vertical view

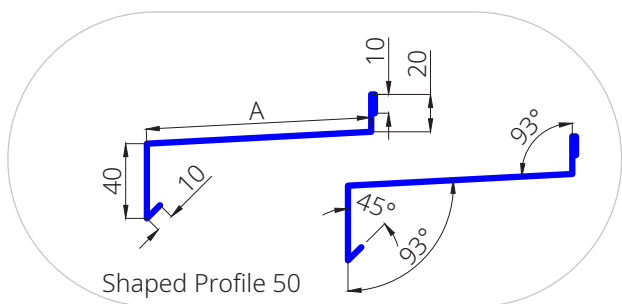
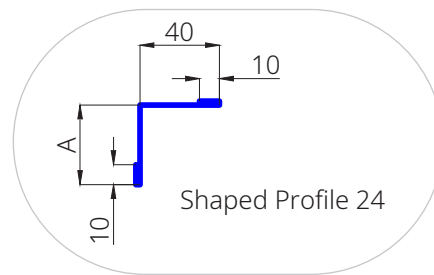
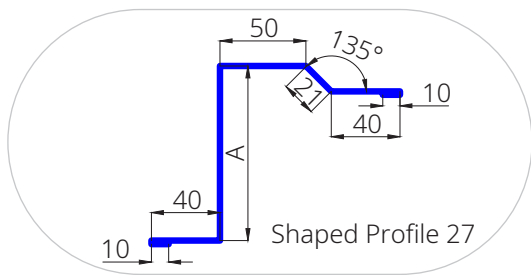
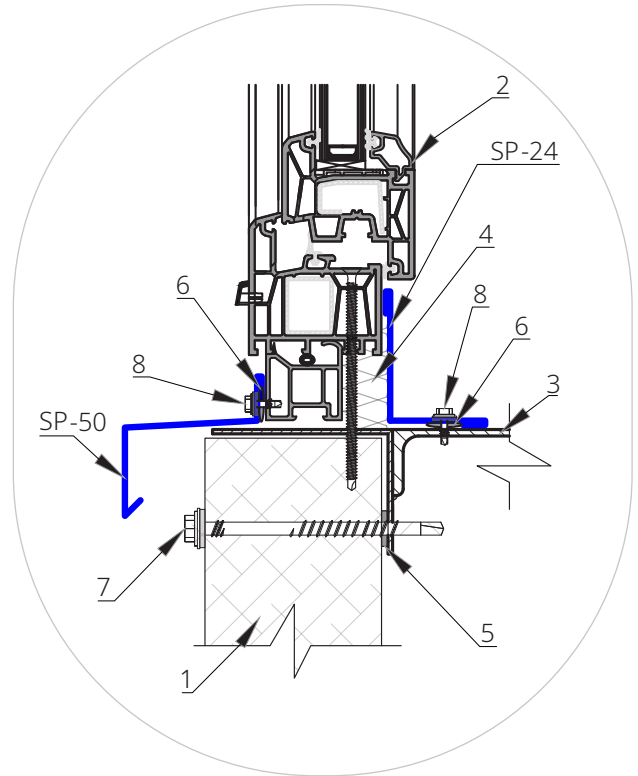
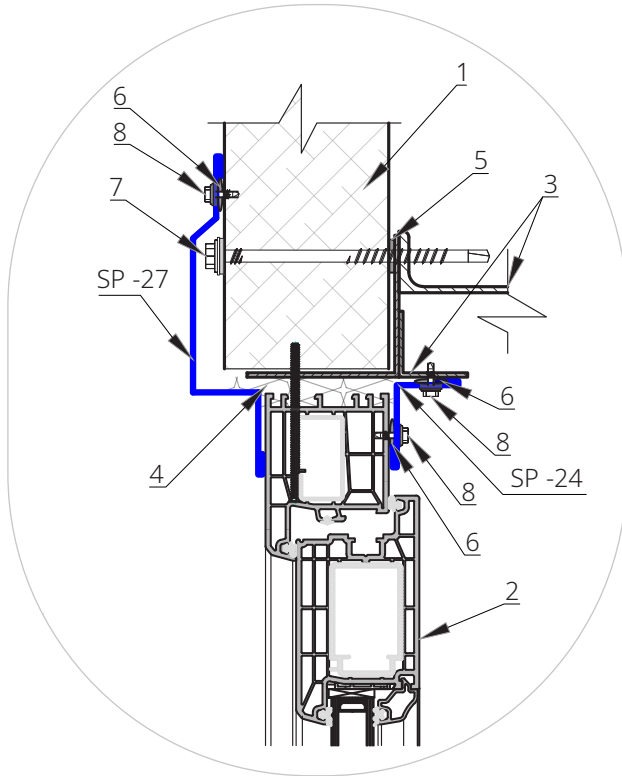

**JOINT 12. WINDOW FRAMING**

- 1. sandwich panel
- 2. window
- 3. metal frame
- 4. sealing foam
- 5. sealing tape
- 6. silicon sealing foam
- 7. self-drilling screw for insulated panels
- 8. self-drilling screw for flashings

Option 3.  
 Window inside sandwich panel, installation to sandwich panel flat on the outside  
 Horizontal view

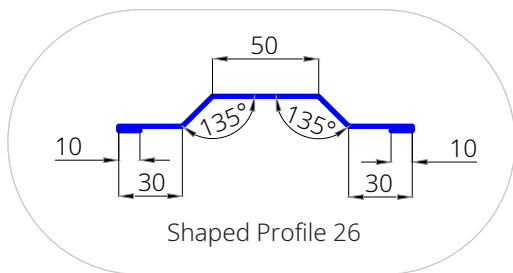
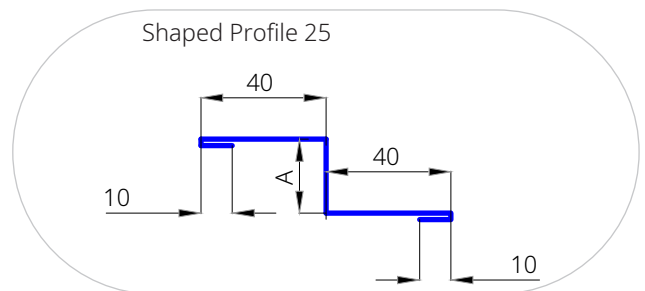
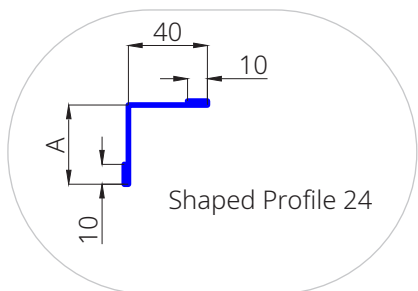
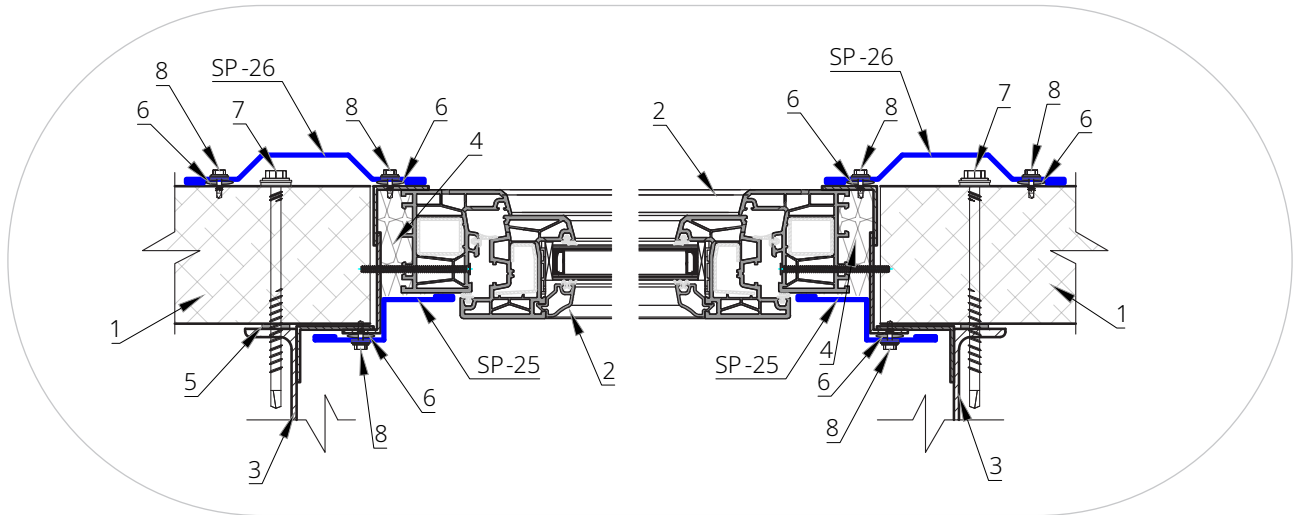



**JOINT 12. WINDOW FRAMING**

- 1. sandwich panel
- 2. window
- 3. metal frame
- 4. sealing foam

- 5. sealing tape
- 6. silicon sealing foam
- 7. self-drilling screw for insulated panels
- 8. self-drilling screw for flashings

Option 3.

Window inside sandwich panel, installation to sandwich panel flat on the outside

Vertical view

